

Rion Hobby Gardener Assembly Instructions



Hobby Gardener™

**Modular greenhouses, garden sheds, outdoor garden elements and accessories
Designed and manufactured by Rion
A Member of the Plasson Group**



THE STANDARDS INSTITUTION OF ISRAEL



THE STANDARDS INSTITUTION OF ISRAEL



THE STANDARDS INSTITUTION OF ISRAEL

Rion Ltd.
Cabri 25120 ● Israel
Tel: +972-4-995-2666, Fax: +972-4-995-2677
email: rion@rion.com
homepage: <http://www.rion.com>

Authorized Rion Distributors

USA

Backyard Living Source, Inc. - BLS

800 South Industry Way, Suite 350
Meridian, ID 83642
☎ +208-287-6601
Fax: 208-287-6602
info@ecogreenhouse.com
www.ecogreenhouse.com

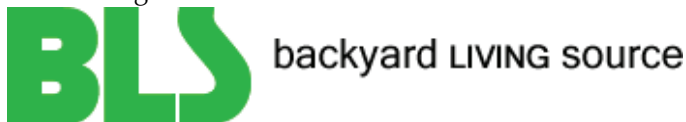

Canada

Canada Greenwall Solutions Inc.

10-8707 Dufferin St., Suite # 384
Vaughan, Ontario, Canada L4J 0A6
☎ +905 597 5710
Fax +905 597 5710
info@greenwallsolutions.com
www.greenwallsolutions.com
www.canada-greenhouse-kits.com



Australia

Oldfields Pty Ltd

8 Farrow Road
Campbelltown N.S.W. 2560
☎ +61 2 4627 0777
Fax: +61 2 4627 0999
sales@oldfields.com.au
http://www.oldfields.com.au/treco/index.htm



Germany

CLEMENS HOBBYTEC GmbH

Rudolf-Diesel-Str. 8
D-54516 Wittlich / Germany
☎ +49 (0) 6571 / 929-222
Fax: +49 (0) 6571 / 929-198
info@clemens-hobbytec.de
www.clemens-hobbytec.de



Korea

Dowin Polychem Co., Ltd

1031-2, Banbaehomestel #209
Bangbae-dong, Seocho-gu
Seoul, Korea
☎ +82-2-583-8511
Fax : +82-2-583-8512
dowin@polygal.co.kr
www.rionkorea.com



South Africa

Easy Greenhouses CC

8 Sherwell Avenue, Boskruin Ext 5
Johannesburg, South Africa 2154
Sales and Support: Linda Hill
☎ +27 11 792 7583
Mobile: +27 82 777 6681
linda@easygreenhouses.co.za
www.easygreenhouses.co.za



Great Britain

Two Wests & Elliott

☎ +01246 451077
Fax: +01246 260115
sales@twowests.co.uk
www.twowests.co.uk



Safety First

- Please read these *Assembly Instructions* completely before assembly and keep them in your records so you can refer to them if you wish to add options or make repairs.
- The instructions in this manual lead you through each step in the assembly process. It is important for you to follow them closely.
- We recommend that you use gloves during assembly.
- Hobby Gardener is not responsible for the misuse of tools or parts.
- If local building codes require permits or licenses make sure that they are acquired before beginning.
- Your Greenhouse should be securely anchored to the prepared foundation using the recommended hardware.
- If you prepare a concrete foundation do not excavate and pour concrete in frozen ground.
- Exercise caution when lifting heavy assemblies.
- Do not attempt to assemble your Greenhouse in high winds.
- We recommend that you place your Greenhouse in a spot where it will receive direct sunlight and will be protected from the wind as much as possible. The door should not face prevailing winds.
- When your Greenhouse is fully assembled examine it for sharp edges and trim with a razor knife if necessary.
- Close all roof vents in high winds.
- It is important to clear your Greenhouse of snow in the winter.
- If you live in a hot climate, where outside temperatures exceed 46° C (115° F) in the sun or 36° C (99° F) in the shade, this may cause the temperature inside the greenhouse to exceed 55° C (131° F). Such conditions may harm your plants and will damage the greenhouse by warping structural profiles. In order to prevent damage:
 - Ensure good ventilation during hot days.
 - Make sure that the temperature inside the greenhouse never exceeds 55° C (131° F) by providing a shading screen, such as the Rion ShadeNet (available as an option).

Note: *Hobby Gardener is not responsible for any damage due to high temperatures.*

Important: **Make sure that you check the contents of the greenhouse packaging against the packing list and the required parts for your model on page 4 and following. Do not begin assembly if any parts are missing.**

Required Tools

Before you start assembly have the following available:

- Power drill
- Measuring tape
- Level
- Scissors
- Gloves
- Awl
- Razor knife
- Sponge and soapy water

Note: *You may find some parts easier to assemble if you first moisten them with soapy water.*

Accessories

Hobby Gardener offers a wide range of accessories for your greenhouse from modular bases for the foundation, automatic window openers, and shelving for your plants.

-

Introduction

Congratulations on purchasing an Hobby Gardener. We are certain that it will give you many happy years of pleasure in your garden.

Hobby Gardener has been designed to be as easy to put together as it is beautiful to look at. Most of the work can be done by a single person. Only attaching the roof requires the help of a family member or neighbor for a short while.

Easy assembly methods eliminate the need for tools or special expertise.

- 1 Connect the specified parts.
- 2 Match the holes in the profiles and the connectors. Place a pin on the pin tool and push the pin through the lined-up holes to lock the parts in place. Many connections require pins on both sides.

Note: Extra pins are included.

- 3 If you wish to disassemble the parts at any time, remove the pins using the pin tool. Place the end into the exposed hole and lever the pin out.
- 4 If a hole in the connector is missing, drill a hole with a 6 mm (1/4") drill bit through the assembled profile and then insert the pin.
- 5 In extremely rare cases connectors will not slip into some round or oval profiles. In this case place the affected part into 10 cm (4") of boiling water for 15 seconds before connecting.

Important: In order to maintain the life of your greenhouse, it is essential to insert glazing elements fully and completely.

- 1 Moisten the glazing element with soapy water.
- 2 Insert one end of the glazing element into the profile until it snaps into place.
- 3 Push the glazing element along its length.
- 4 Continue until the end of the glazing element snaps in place. The callout (5) shows an enlarged cross-section of the profile and glazing element when it is seated correctly

Greenhouse assembly is done in the following steps:

- Prepare a Foundation for Your Greenhouse (page 3)
- Identify Greenhouse Parts (page 4)
- Prepare Your Parts for Assembly (page 7)
- Lay Out the Greenhouse Frame (page 8)
- Secure the Frame to the Foundation (page 9)
- Assemble the Roof Pediments (page 10)
- Assemble Roof Framework (page 12)
- Cover the Greenhouse Roof (page 13)
- Cover the Walls (page 17)
- Raise the Roof (page 18)
- Seal Panels (page 19)
- Prepare Doorway (page 19)
- Assemble the Doors (page 20)
- Hang the Doors (page 21)
- Assemble Door Latches (page 22)
- Seal the Door (page 23)
- Final Touches (page 24)

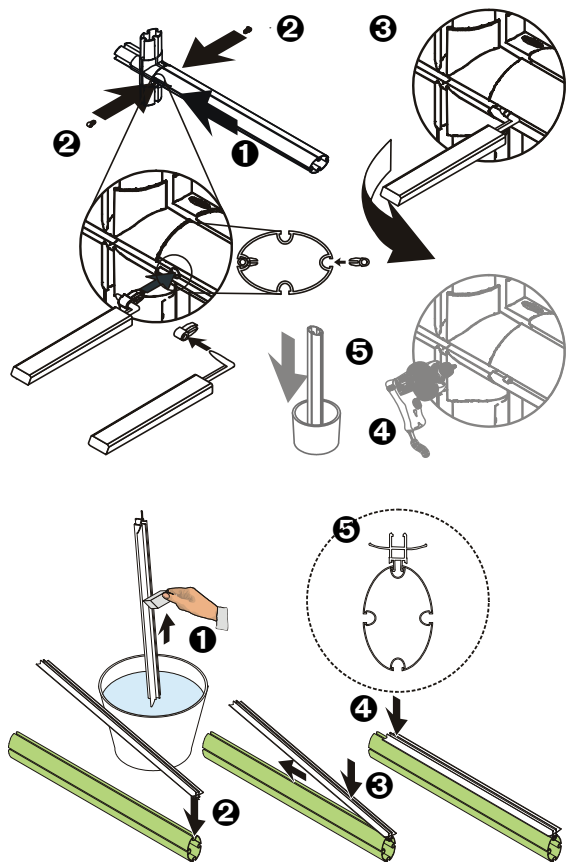

Prepare a Foundation for Your Greenhouse

Before assembling your new Greenhouse a proper foundation must be prepared. A number of anchoring options are possible, based on wind and ground conditions in your area. Make sure that you have checked with your local authorities regarding any required building permits.

Decide at this time the final orientation of your Greenhouse. We recommend that you place your greenhouse in a spot where it will receive direct sunlight and will be protected from the wind as much as possible. The door should not face prevailing winds. It is important to clear your Greenhouse of snow in the winter.

Modular Base (Option)

If you have purchased the optional Greenhouse Modular Base follow the assembly instructions in the packaging. The Greenhouse Modular Base can be placed in an excavated hole or on the ground. In either case you will require sufficient gravel, earth or other suitable material to fill the base (see table below). All required hardware is included.

Rion Resin Greenhouse Base

If you have purchased the optional Rion Resin Greenhouse Base follow the assembly instructions in the packaging. The Greenhouse Modular Base can be placed in an excavated hole or on the ground. In either case you will require sufficient gravel, earth or other suitable material to fill the base (see table below). All required hardware is included.

Treated Wood Base

Build a framework composed of 4 × 6 (❶) and 2 × 12 (❷) treated lumber using deck screws or galvanized lag bolts and fill it with gravel or earth or other suitable material to fill the base up to the top surface of the 4 × 6 (❶). Attach the greenhouse frame through the connectors using screws that are 6 mm (1/4") in diameter and no less than 70 mm (2 3/4") long (not supplied).

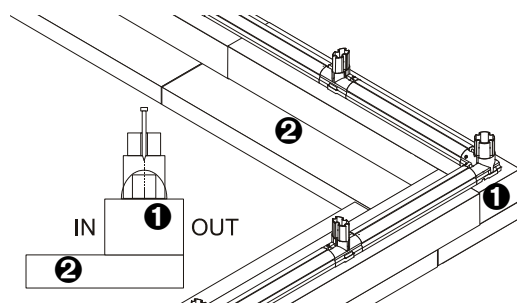

Model	Base Width	Base Length	Fill Quantity	Screw/Lagbolts
HG 8' x 8'	2.65 meter (8' 8 5/8")	2.65 meter (8' 8 5/8")	0.68 cubic meters (24 cubic feet)	20
HG 8' x 12'	2.65 meter (8' 8 5/8")	3.90 meter (12' 9 9/16")	1.02 cubic meters (36 cubic feet)	28
HG 8' x 16'	2.65 meter (8' 8 5/8")	5.14 meter (16' 10 3/8")	1.36 cubic meters (48 cubic feet)	36

Note: You may assemble the greenhouse on its base on a hard surface and move it to its final position when you have finished. Make sure that there are no obstructions between the assembly area and the final position.

Other Foundation Options

Wood Deck

Your Greenhouse can be secured to a wood deck with screws (not supplied) through the frame connectors. Use screws that are 6 mm (1/4") in diameter and no less than 70 mm (2 3/4") long. Make sure that the wood deck itself is securely anchored to the ground. See hardware quantities and foundation measurements above.

Excavated Trench

Your Greenhouse can be placed in an excavated trench to anchor it to the ground. See the foundation measurements above for dimensions.

Concrete Foundation

Prepare a poured concrete foundation according to local building codes. Do not excavate and pour concrete in frozen ground. Make sure that there is a slight slope for drainage.

Pour your foundation according to the size of the greenhouse model you have selected. Make sure that the foundation is at least 10 cm (4") larger than the size of the greenhouse. The Greenhouse is secured to the concrete foundation using screws and concrete anchors or expansion anchors (not supplied). Use screws 6 mm (1/4") in diameter and no less than 70 mm (2 3/4") long. A drill with an appropriate masonry bit is required.

Model	Middles	Foundation Width	Foundation Length	Expansion Anchor Sets
HG 8' x 8'	HGF + HGB + HGM	2.70 meter (8' 10")	2.70 meter (8' 10")	20
HG 8' x 12'	HGF + HGB + HGM (2)	2.70 meter (8' 10")	3.95 meter (12' 11")	28
HG 8' x 16'	HGF + HGB + HGM (3)	2.70 meter (8' 10")	5.20 meter (17')	36

Identify Greenhouse Parts

Because of the Greenhouse modularity, you may purchase additional HGM double Middles to fit your needs.

Note: HGM single Middles are also available.

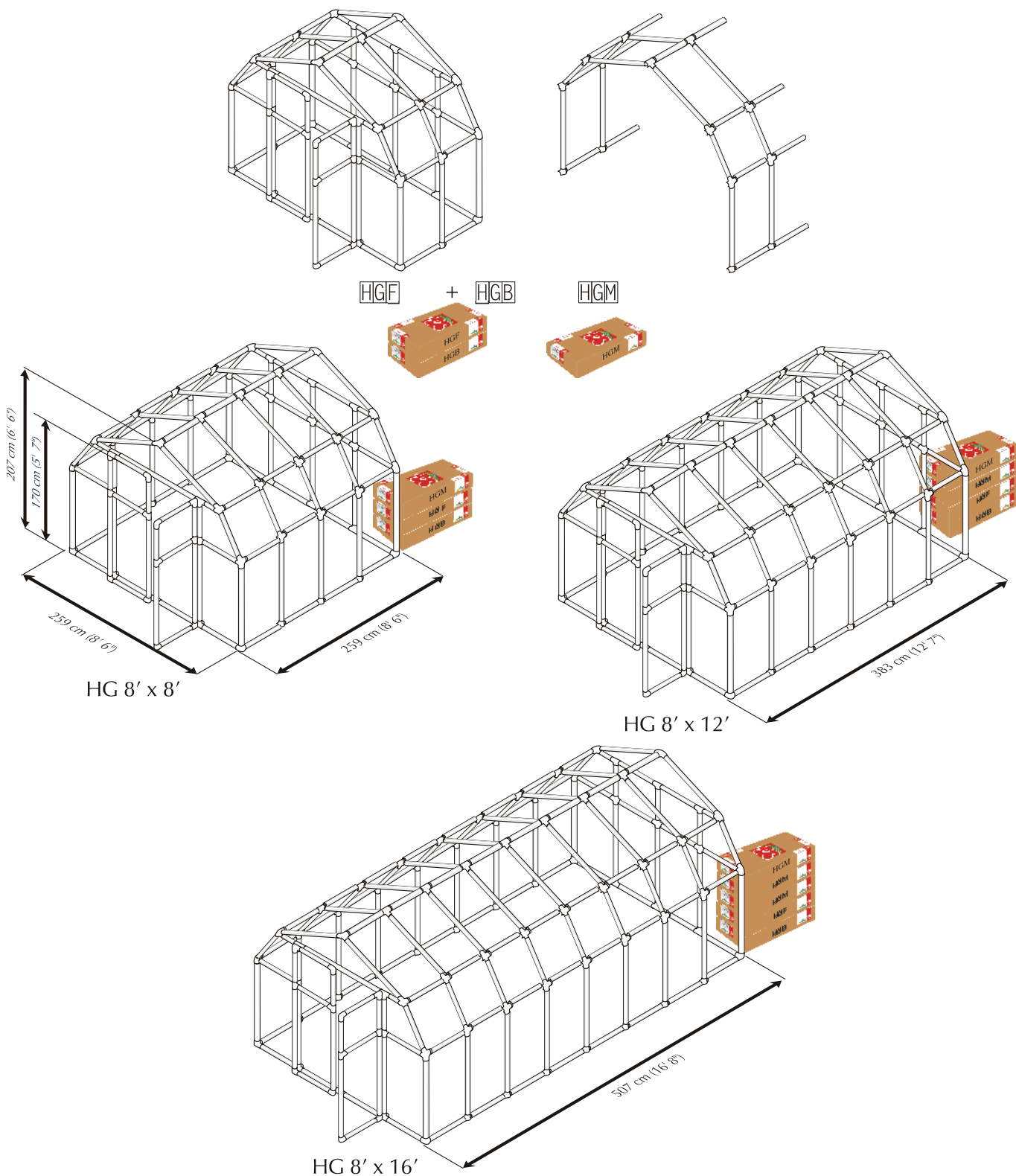



Take a minute to make sure you have everything you need.







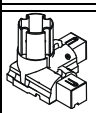
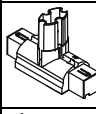
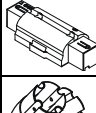
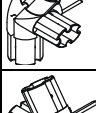
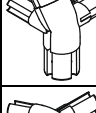
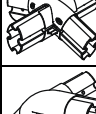
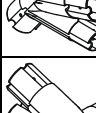
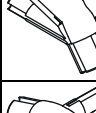
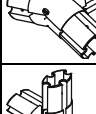
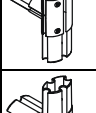
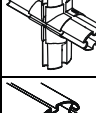
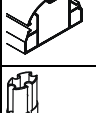
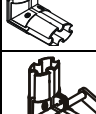
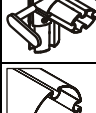
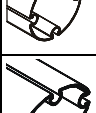





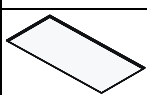
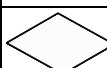
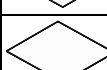
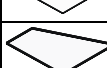

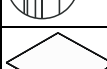
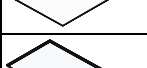

Note: Do not proceed with assembly if any parts are missing.

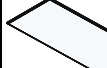
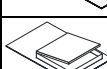
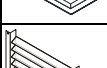
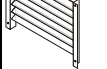
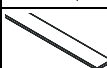









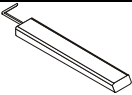

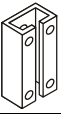
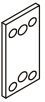

The part code is stamped on each connector. Profiles are listed in order by size, largest to smallest. Panels are identified with stickers.

Exact dimensions can be found in the packing list.

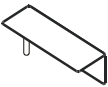
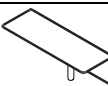
The drawings in this manual are designed for the greenhouse owner who has purchased a Greenhouse 8' x 8', which consists of one front unit (HGF), and one back unit (HGB) and one HGM (Middle) unit. If you have purchased additional Middles the instructions are indicated in the text.

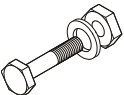
	Part Code	Front	Back	Middle	Description
	01	2	2	0	Corner Frame Connector
	2D	3	4	4	Frame Connector
	15	1	0	0	Doorway Frame Connector
	3A	1	1	0	Left Rib Connector
	4A	1	1	0	Right Rib Connector
	5A	3	2	10	Rib Connector
	6A	1	1	0	Left Pediment Connector
	7A	1	1	0	Right Pediment Connector
	8A	1	1	0	Top Pediment Connector
	09	7	3	0	T-Oval Connector
	10	0	3	0	Oval Junction Connector
	B2	6	6	4	Base Profile (50 cm, 1' 7 ¹ / ₆ ")
	18	4	0	0	Corner Oval Connector
	18D	4	0	0	Corner Oval Connector (Door)
	DoorH33	1	0	0	Door Handle
	R1	2	2	0	Round Profile (113 cm, 3' 8 ¹ / ₂ ")
	R8	2	2	0	Round Profile (80.2 cm, 2' 7 ⁹ / ₆ ")
	R2	2	2	0	Round Profile (53.4 cm, 1' 9")
	E12	1	0	0	Oval Profile (116.2 cm, 3' 9 ³ / ₄ ")
	E1	7	4	4	Oval Profile (113 cm, 3' 8 ¹ / ₂ ")
	E6	1	1	4	Oval Profile (85 cm, 2' 9 ⁷ / ₆ ")
	E2	14	12	14	Oval Profile (54 cm, 1' 9 ¹ / ₄ ")
	E4	6	3	0	Oval Profile (39.4 cm, 1' 3 ¹ / ₂ ")
	E5	2	2	0	Oval Profile (13.4 cm, 5 ¹ / ₄ ")
	SR1	2	0	0	Inner Round Profile (40 cm, 1' 3 ³ / ₄ ")

	Part Code	Front	Back	Middle	Description
	D1	1	1	0	Side Cap
	D2	1	0	2	Middle Cap
	PN1	6	6	4	Wall Panel - (59.7 × 118.3 cm) (1' 11½" × 3' 10⅞")
	PN2	0	0	4	Lower Roof Panel - (60.5 × 66.7 cm) (1' 11⅜" × 2' 2¼")
	PN2A	2	2	0	Lower Roof Panel (side) - (61.7 × 66.7 cm) (2' ⅝" × 2' 2¼")
	PN5L	1	1	0	Side Panel (Left) - (58.1 × 44.9 cm) (1' 10⅞" × 1' 5⅛")
	PN5R	1	1	0	Side Panel (Right) - (58.1 × 44.9 cm) (1' 10⅞" × 1' 5⅛")
	PN8R	1	1	0	Pediment Panel Half (Right)
	PN8L	1	1	0	Pediment Panel Half (Left)
	ST7	2	2	0	Window Couplers
	PN9	2	1	0	Upper Back Wall Panel - (59.9 × 44.7 cm) (1' 11⅞" × 1' 5⅜")
	PN40	0	0	3	Top Roof Panel - (60.5 × 97.6 cm) (1' 11⅜" × 3' 2⅜")
	PN40A	2	2	0	Top Roof Panel (outside) (61.7 × 97.6 cm) (2' ⅝" × 3' 2⅞")
	WIN33	0	0	1	Roof Vent
	WINH31	0	0	1	Roof Vent Handles (packages of 2)
	Louver	0	1	0	Back Pediment Louver Window
	GSC10	0	2	0	Back Pediment Strengthening Bar
	GSE12 (inside E12)	1	0	0	Front Pediment Strengthening Bar
	DSN	1	0	0	Door Sealer (roll)
	WDS	2	0	0	Door Frame Sealer
	GF	1	1	1	Flexible Glazing Seal (roll)
	RA1	1	1	2	RA Glazing Element (57.3 cm, 1' 10⅞")
	RB4	1	1	4	RB Glazing Element (84.8 cm, 2' 9⅜")
	RB6	2	2	0	RB Glazing Element (80 cm, 2' 7½")
	RB1	3	3	4	RB Glazing Element (52 cm, 1' 8½")
	RC5	3	3	4	RC Glazing Element (95.5 cm, 3' 1⅝")
	RC1	3	3	4	RC Glazing Element (66.6 cm, 2' 2¼")
	RC3	1	1	2	RC Glazing Element (58 cm, 1' 10⅜")
	RD1	4	4	8	RD Glazing Element (56.9 cm, 1' 10⅜")
	PIN1	160	160	120	Connector Pin

	Part Code	Front	Back	Middle	Description
	GT1	1	1	0	Pin and Glazing Tool
	SF	1	1	1	Soft Foam Roof Insulation (roll)
Bar Kit					
	Latch	2	0	0	Inner Door Latch
	UBC	1	0	0	Upper Bar Connector
	LBC	1	0	0	Lower Bar Connector
	PS 1/14"	4	0	0	Inner Door Latch Screw
	PH Screw	9	0	0	Pan Head Latch Screw
	Door Holder	2			Hook Latch and Eye
Easy GH Screw Kit					
	DR	1	0	0	Bottom Right Hinge
	DL	1	0	0	Bottom Left Hinge
	Upper Hinge Right Door-1	1	0	0	Upper Hinge for Right Door
	Upper Hinge Left Door-1	1	0	0	Upper Hinge for Left Door
	AS80	4	0	0	Screw
	ASL80	4	0	0	Wingnut
	ASM80	4	0	0	Washer
Bolt Kit					
	BKN	4	0	0	M6 Nut
	BKW	4	0	0	M6 Washer
	BKB	4	0	0	M6 X 50mm Bolt
SUPP1/2					
	AS 70	2	0	4	Cable screw
	AW5	1	0	0	Allen Wrench
	Hook1	1	0	2	Top Catch
	CAB40	1	0	2	Cable

Prepare Your Parts for Assembly

Remove everything from your packages and sort them according to part type. Since assembly is done from taking parts from every box, it is best to put everything together. The boxes are printed with a ruler to help you distinguish between profiles.

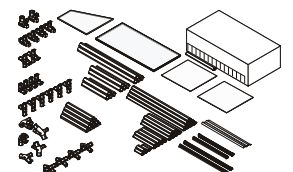

Note: Protect unassembled panels from the sun to prevent identification stickers from adhering to the glazing.

Lay Out the Greenhouse Frame

Decide in which direction the door will face and place the parts on the prepared foundation or wood deck.

Note: If you are using a modular base or other foundation option (see page 3) assemble the base on a flat surface (such as a driveway or a garage) and then move it into position when you are done.

- 1 Slide the SR1 profiles into the two B2 frame profiles that will be used for the doorway.
- 2 Take the 15 connector and place it with the latch hole facing the outside, as shown.
- 3 Place the two prepared B2 frame profiles on either side of the 15 connector.
- 4 Attach the DL bottom left hinge to a 2D connector with two BKB bolts. Secure the hinge with a BKW washer and a BKN nut and then snap the 2D connector and hinge to the left side of the prepared B2 frame profile.

Note: Arrange all 2D connectors with the stamped word **OUT** facing the outside of the greenhouse.

- 5 Attach the DR bottom right hinge to a 2D connector with two BKB bolts. Secure the hinge with a BKW washer and a BKN nut and then snap the 2D connector and hinge to the right side of the prepared B2 frame profile.
- 6 Place the other parts of the frame in place and push them together. Make sure that the channel of the 2D connectors faces outward. Each base connector is stamped with an arrow pointing to the outside direction.
- 7 Lock the frame together with pins.

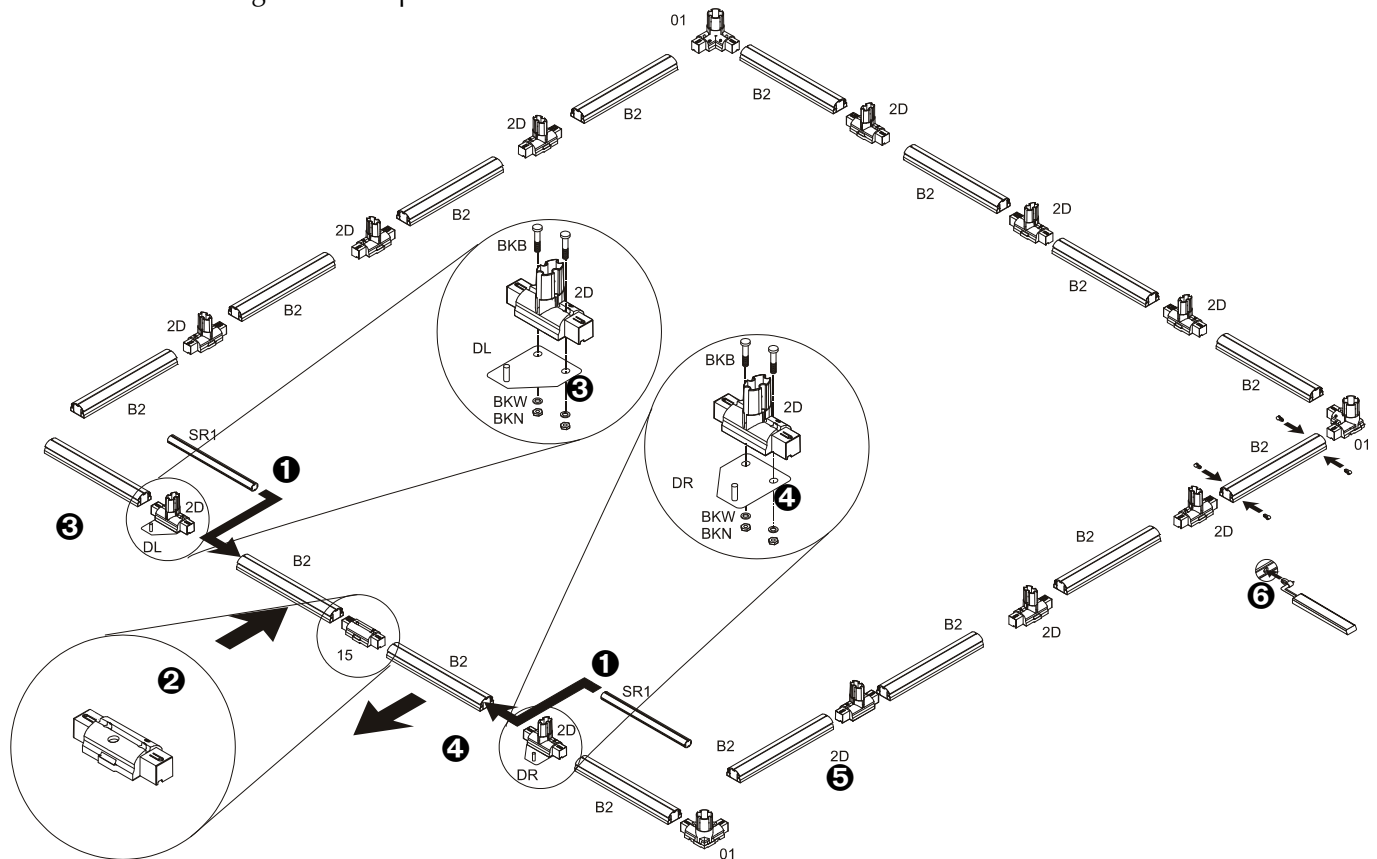

- 8 Make sure that the frame is perfectly rectilinear by measuring the diagonals and verifying that they are the same.

- 9 Use a spirit level to make sure that the frame is level.

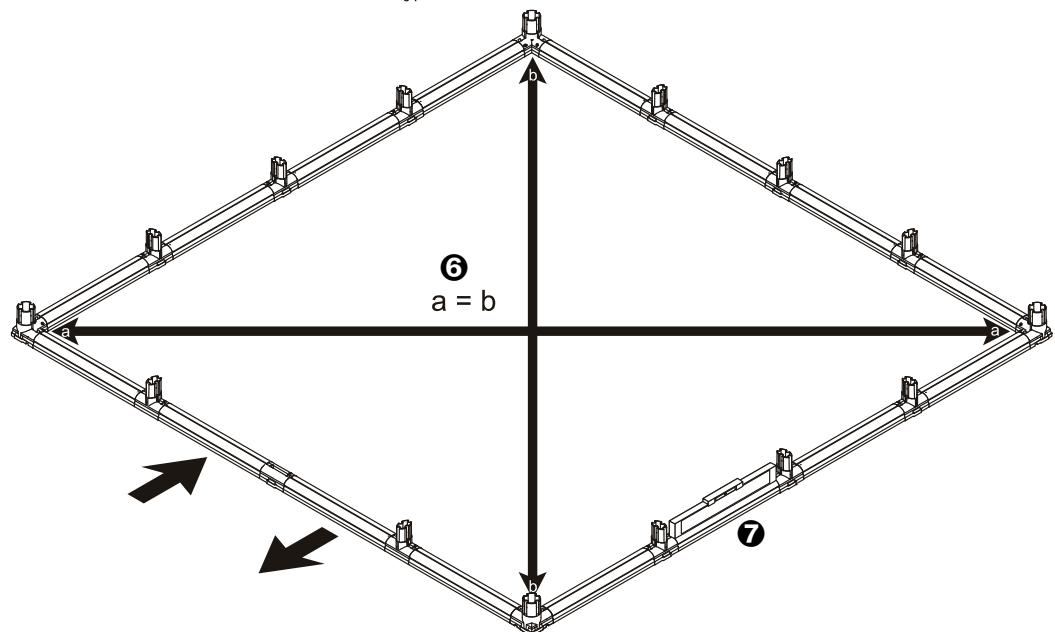

Secure the Frame to the Foundation

Make sure you have the proper hardware before beginning this step. (See page 3.)

Note: If you are using a modular base and filler you may assemble the greenhouse on a hard surface and move it to its final position when you have finished. Make sure that there are no obstructions between the assembly area and the final position.

Rion Resin Greenhouse Base, Wood Deck, or Treated Foundation

Insert screws into the frame connector holes and secure them to the base.

Note: If you have purchased the optional Rion Resin Greenhouse Base all necessary hardware is included.

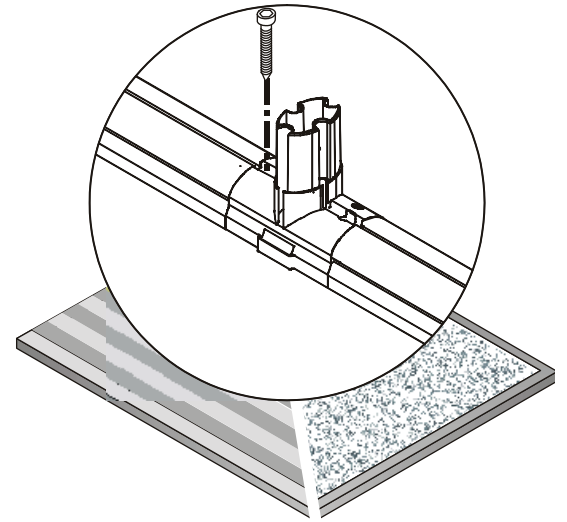

Concrete Foundation

- 1 Mark the foundation through each connector using a scribe or screw.
- 2 Carefully move the frame and then drill holes using an appropriate masonry bit. Insert concrete anchors or expansion anchors (not supplied) in each hole.
- 3 Move the frame back into place. Make sure that it is still perfectly rectilinear. Secure the screws/anchors in place.

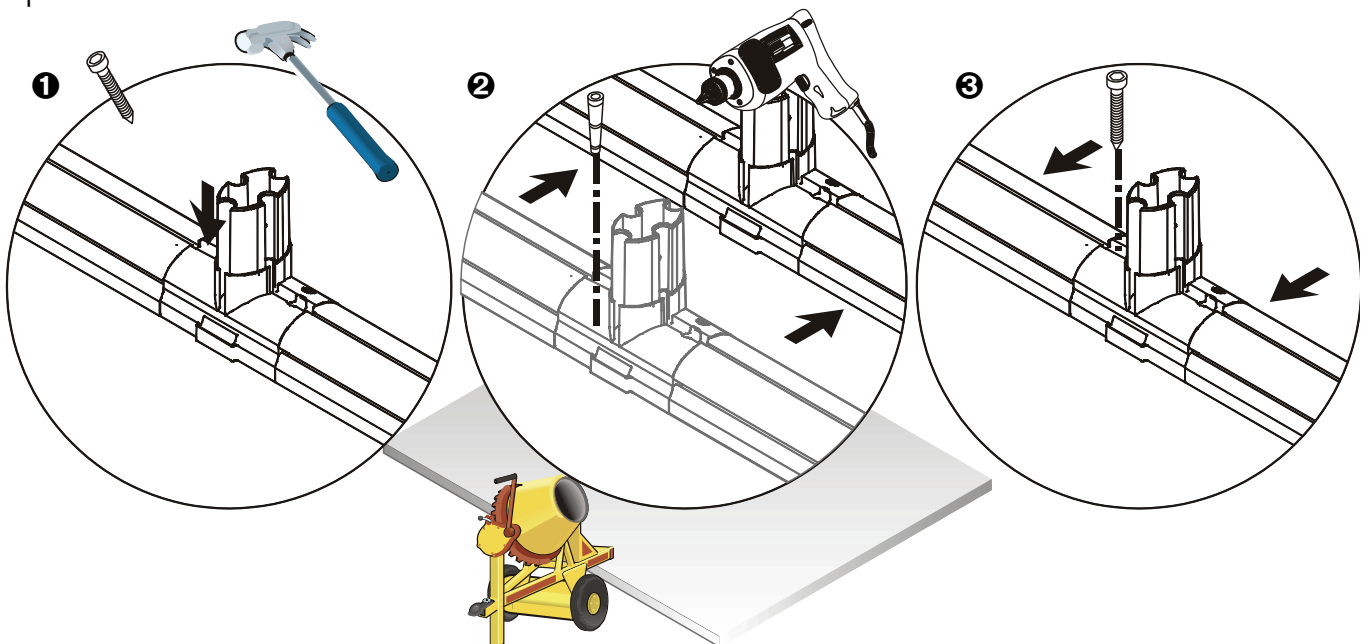

Assemble the Roof Pediments

- Put ST7 couplers on the PN8R and PN8L pediment panel halves as shown. The tops of each coupler are trimmed to match the angle of the panel.

Note: The outside surface of the panels have special UV protection, indicated by the logo and the plastic identification strip. Remove plastic ID strips as panels are locked in place.

- Slide the two pediment panel halves together.
- Assemble the left half of the front pediment.
- Attach the E12 profile to the 09 connector. The GSE12 Strengthening Bar, which is inside the profile, slides into the 09 connector.

Note: There is a sticker indicating the left side of the E12 profile.

- Assemble the second 09 connector to the E12 profile.
- Slide the assembled PN8R/PN8L pediment panel into the open space of the pediment.
- Complete the front pediment, taking advantage of the flexibility of the profiles.
- Lock the pediment in place using pins and remove the ID strips from the panels.

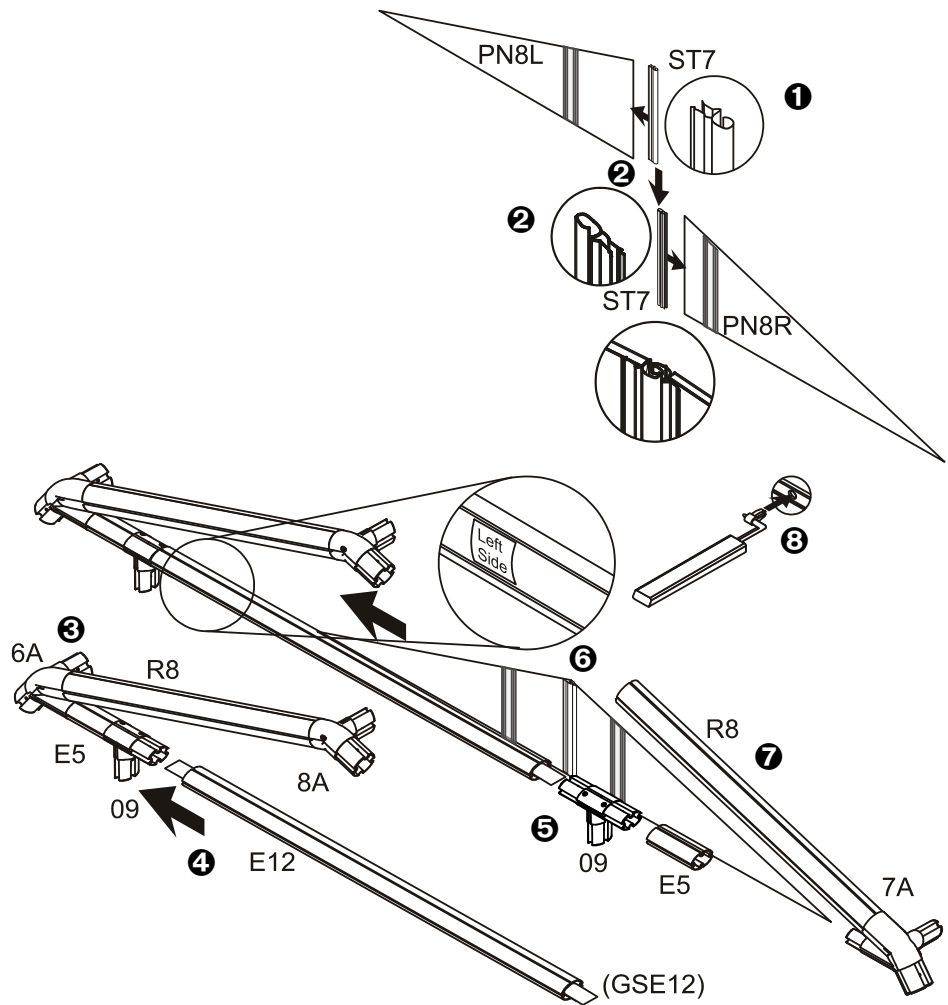

Complete Doorway Pediment

- Attach an E4 and R2 profiles to the lower right pediment.
- Slide the PN5R panel in place. Make sure that the plastic ID strip faces out.
- Connect the 4A and 09 connectors to an E2 profile and put it in place taking advantage of the flexibility of the profiles.
- Lock the panel with pins.
- Assemble the lower left pediment in the same way.
- Remove the ID strips from the panels.

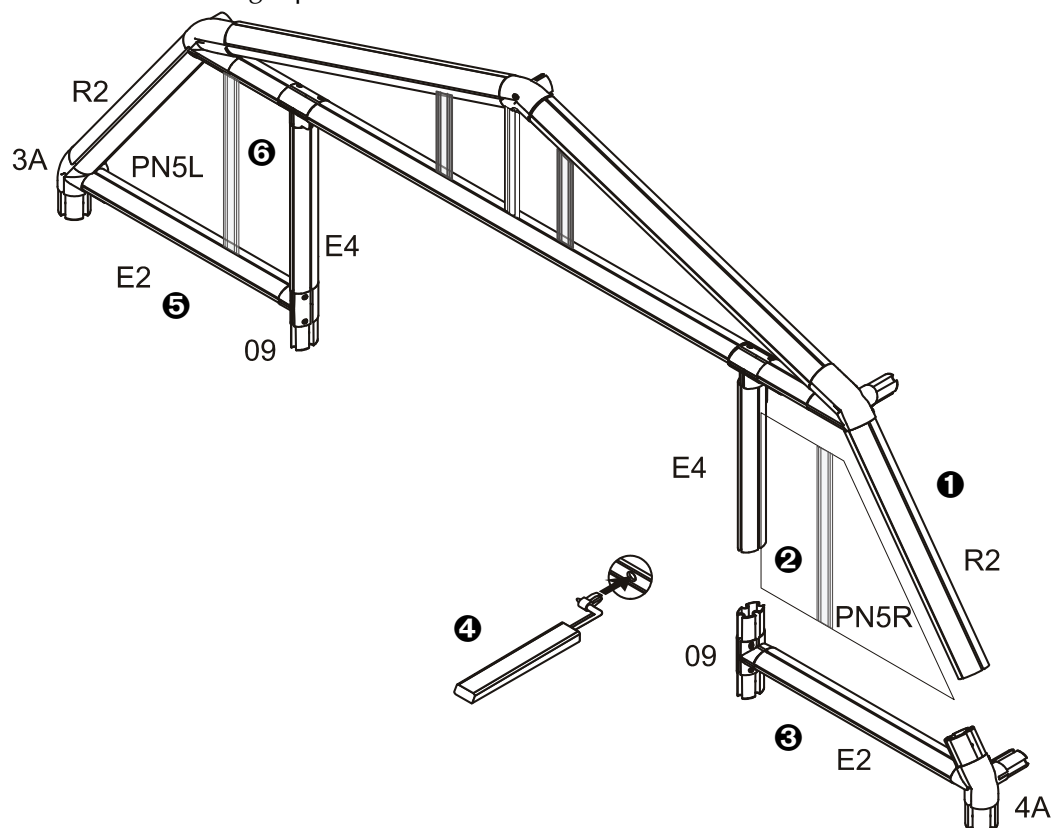

Back Pediment

- ❶ Put ST7 couplers on the PN8R and PN8L pediment panel halves with the ID plastic strip facing out. The tops of each coupler are trimmed to match the angle of the panel. Slide the two pediment panel halves together.
- ❷ Assemble all parts of the back pediment except for the 7A connector and the R8 profile and slide the assembled PN8R/PN8L pediment panel into the open space of the pediment. Complete the back pediment, taking advantage of the flexibility of the profiles.
- ❸ Lock the pediment in place using pins and remove the ID strips from the panels.

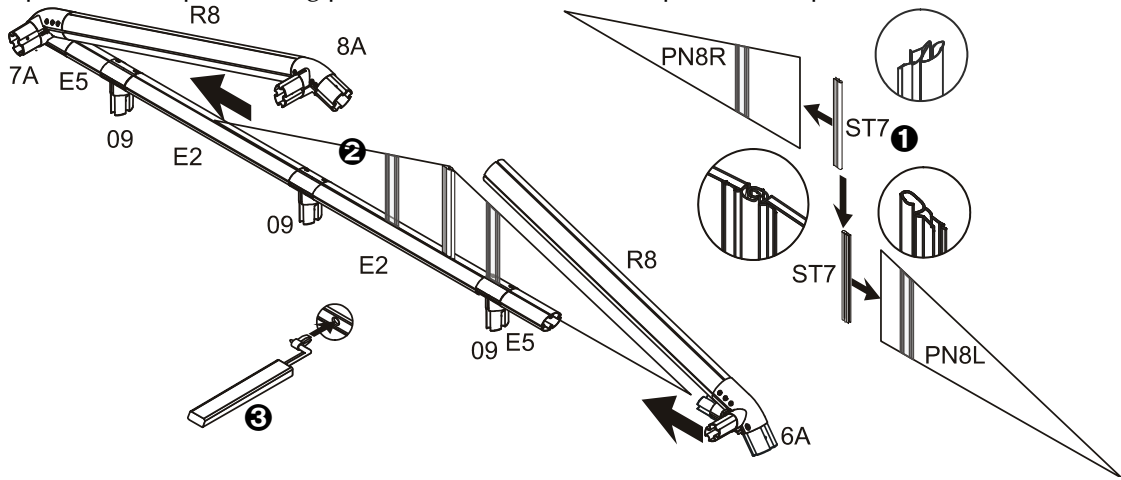

- ❹ Hold a 10 connector with the identifying "10" on top and insert two GSC10 strengthening bars at an angle, as shown, from each side. They overlap inside the connector with their ends flush with the far end.

Note: The strengthening bars cannot be inserted all the way if the identifying "10" is not on top.

- ❺ Slide two E2 profiles over the GSC10 strengthening bars. The ends of the strengthening bars extend beyond the E2 profiles.
- ❻ Complete the back pediment support with 10 connectors, E2 profiles and 4A and 3A connectors as shown.
- ❼ Put the remaining profiles on the back pediment top.
- ❽ Insert the Louver Window in one of the central sections, as shown, sliding the four attached screws into the pinholes in the connectors.
- ❾ Turn the screws with a screwdriver until the Louver is in place.

Note: If you have purchased an additional Louvered Windows insert it instead of the second PN9 panel.

- ❿ Slide the rest of the back pediment panels in as shown. Make sure that the plastic ID strip faces the outside.
- ⓫ Put the back pediment support in place, taking advantage of the flexibility of the profiles.
- ⓬ Lock everything into place using pins and remove the ID strips from the panel.

Note: Do not remove the protection elements from the Louvered Window until the roof assembly is complete.

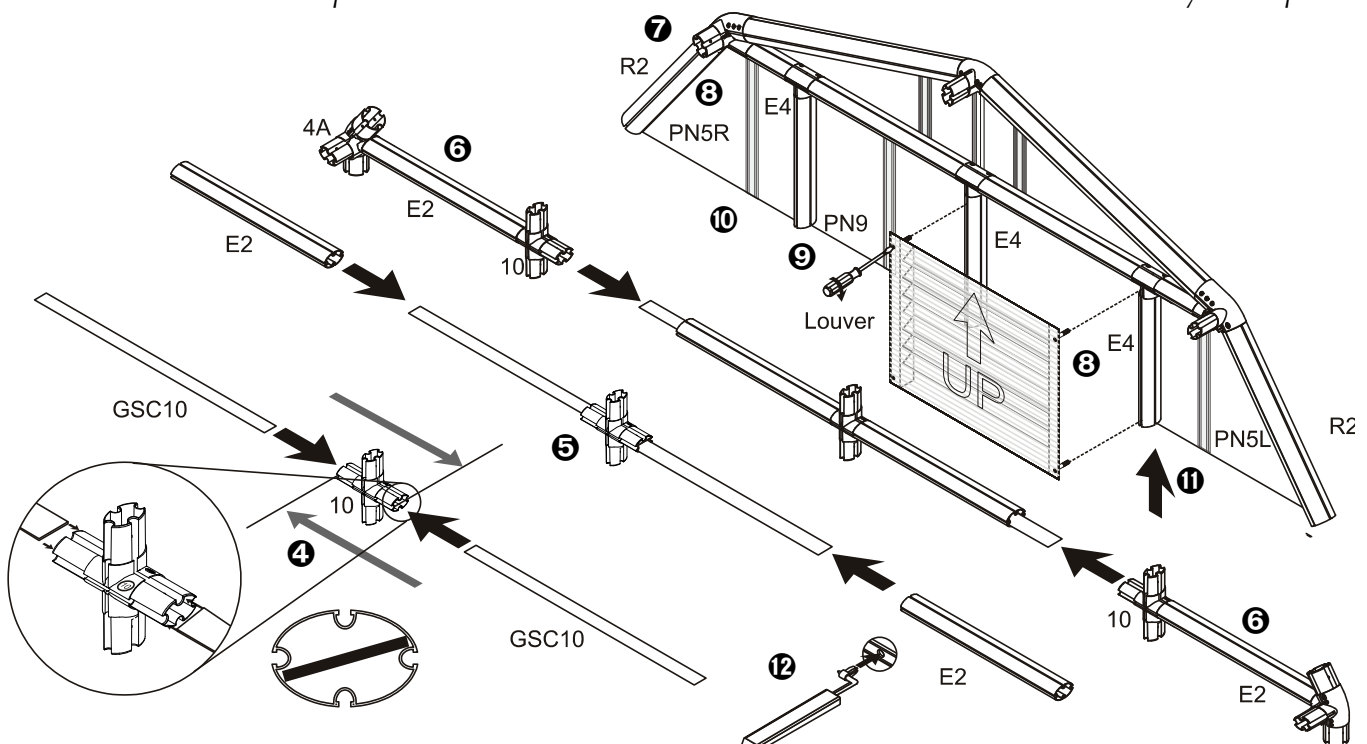

Assemble Roof Framework

Note: Assemble the roof in an area not too far away from the completed base.

- 1 First assemble the first arch.
- 2 Slip one end of the CAB40 cable through the 6 mm (1/4") channel on the underneath side of the 5A connector. You may use the GT1 pin and glazing tool to assist you. **The cable does not go through the central hole of the connector.**
- 3 Screw an AS70 screw using the AW5 Allen wrench through the CAB40 cable and the pin holes in both sides of the connector.

Note: The end of the screw should not extend beyond the outside channel of the E2 profile so it won't interfere with the placement of the RB1 glazing element (page 13).

- 4 Repeat the previous two steps for the 5A connector on the other side of the arch.
- 5 Lock the parts in place using pins.
- 6 Repeat steps 1 through 5 for the rest of the arches according to the number of HGM Middles you have purchased.

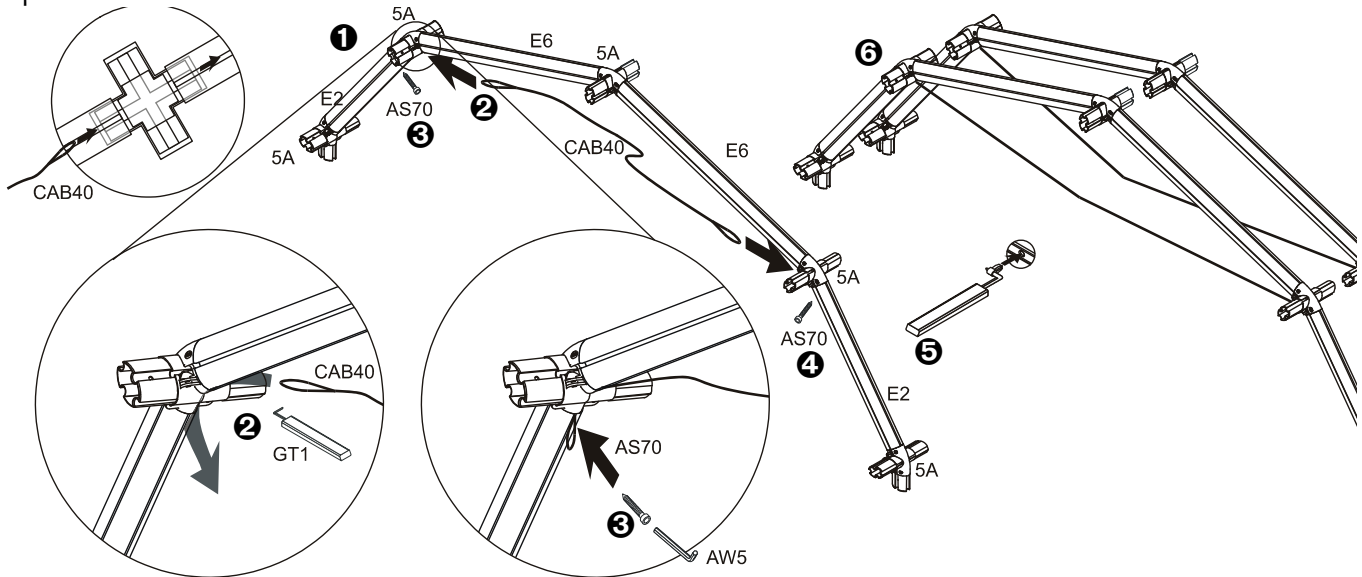

- 7 Grasp the center of each CAB40 cable with the Hook1 Top Catch and slide it into the top 5A connector as shown.

- 8 Add E2 profiles to the front pediment and lock the parts in place using pins.

- 9 Add E2 profiles to the completed ribs according to the number of Middles you have purchased and lock them into place with pins.

- 10 Complete the roof by attaching the back pediment. Lock it into place with pins.

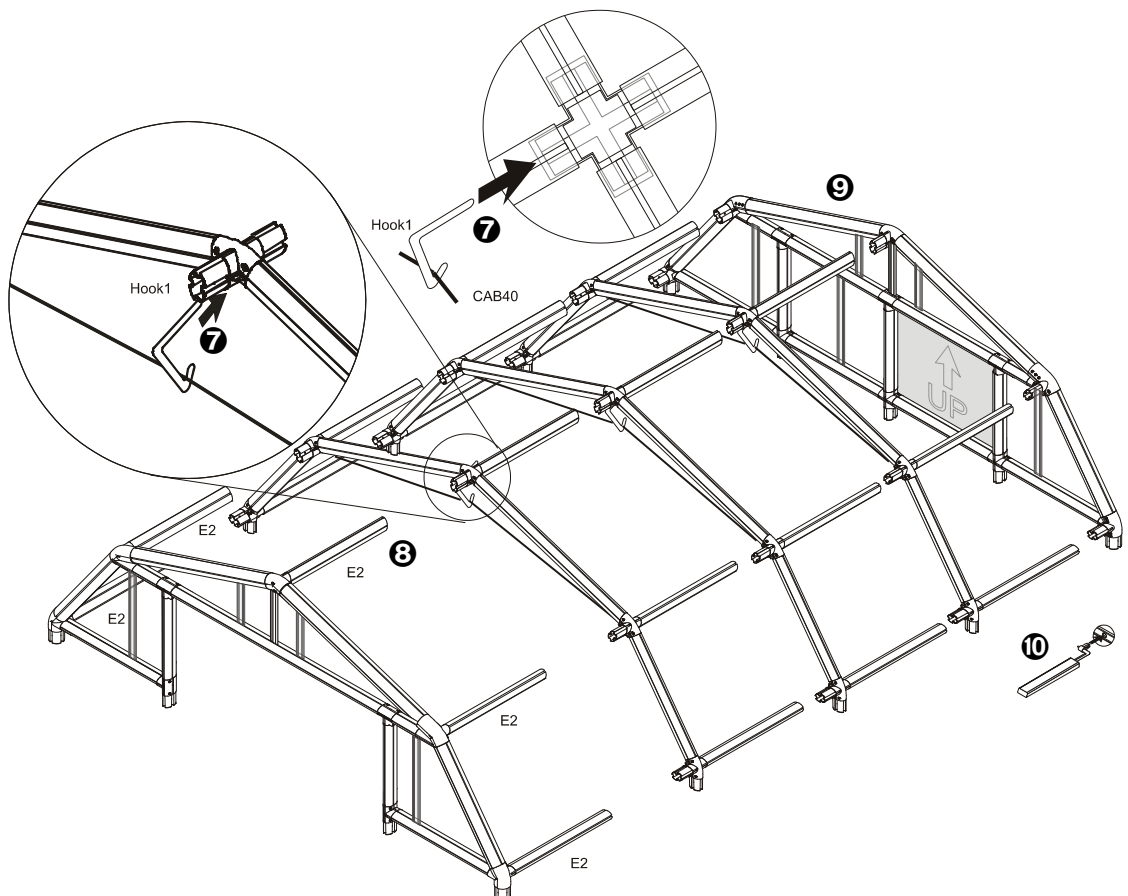

Cover the Greenhouse Roof

- ❶ Step in the framework of the lower window to reach the top of the roof conveniently.
- ❷ Place RA1 glazing elements on the top of the roof by placing one end in the top channel and pushing it down along the length of the profile.

Important: In order to maintain the life of your greenhouse, it is essential to insert glazing elements fully and completely, using soapy water, as explained on page 2.

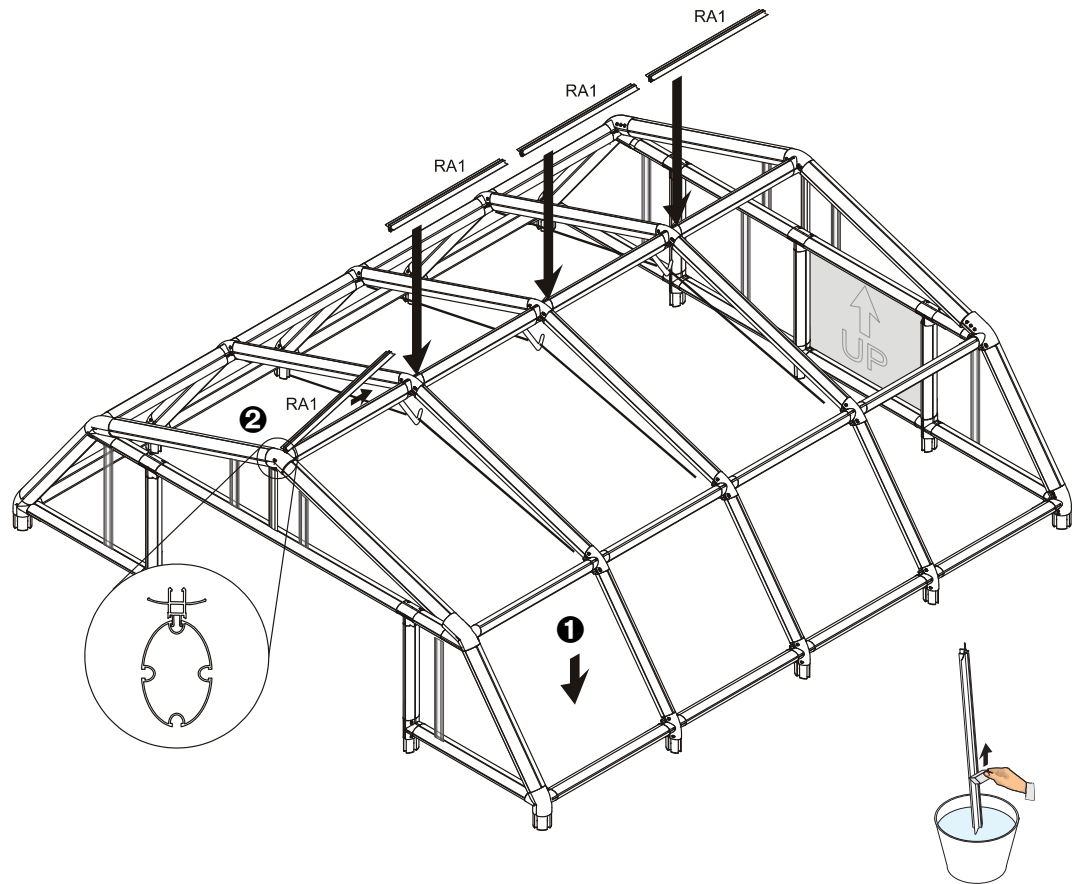

- ❸ Place RB1, RB4, and RB6 glazing elements along the arches where shown. Place one end of the RB elements in the channels of the profiles and slide them down the length of the profile.

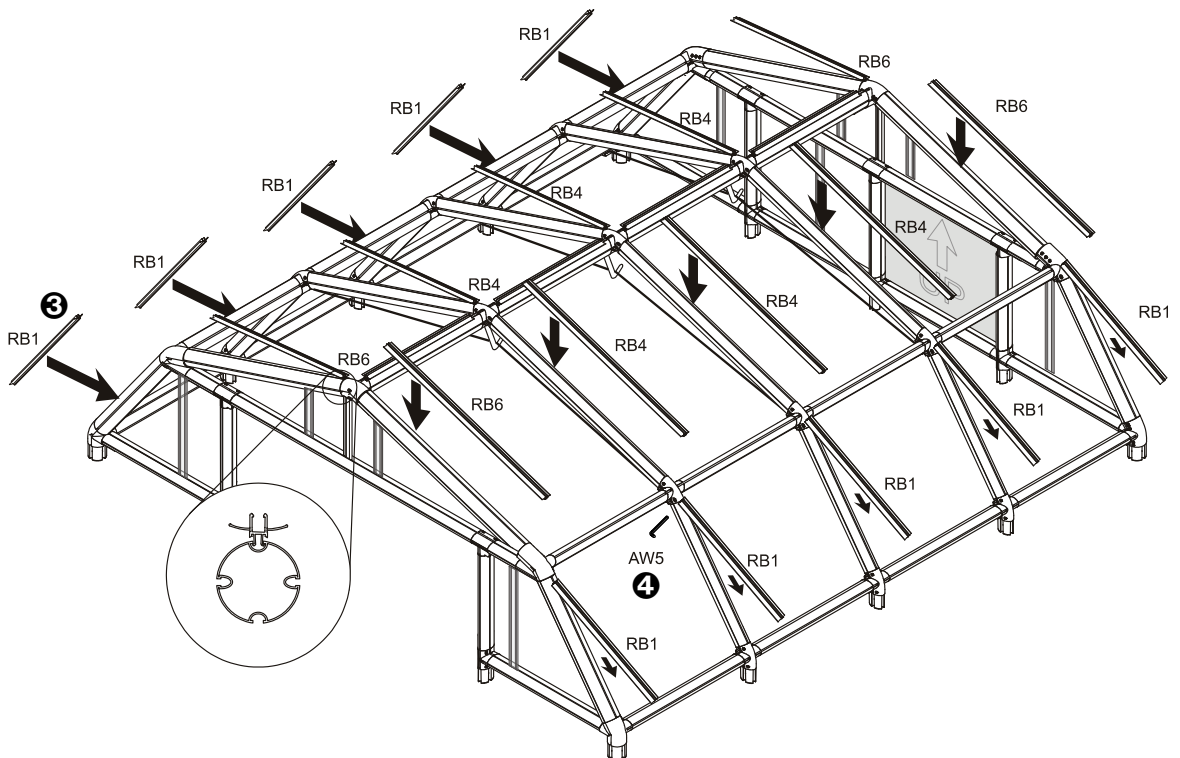

Note: If you have difficulty inserting the top of the RB1 glazing element slightly loosen the AS70 screw holding in the CAB40 cable.

- ❹ Tighten the AS70 screws holding the CAB40 cables with the AW5 Allen wrench.

- Place RD1 elements where shown by placing one end in the channel and pushing it down along the length of the profile.

Note: You may find it easier to insert RD elements into profiles by pushing them in from the top while rolling the element downwards.

Important: In order to maintain the life of your greenhouse, it is essential to insert glazing elements fully and completely, using soapy water, as explained on page 2.

- Place the four PN40A side panels in place by sliding one corner into the RD1 glazing element. Continue until they are fully inserted.

- Decide which of the inner Middles to use for the Roof Vent.

Note: The Roof Vent cannot be inserted in the outside spaces.

- Assemble the two WINH31 handles to the WIN33 Roof Vent using the included pins.

- Insert the Roof Vent in one of the remaining central spaces by sliding one corner into the RD1 glazing element.

Note: Additional Roof Vents are available as an option.

- Install the remaining PN40 panels and remove the ID strips from the panels.

Caution: Close windows in high winds. Automatic window openers are available as an option.

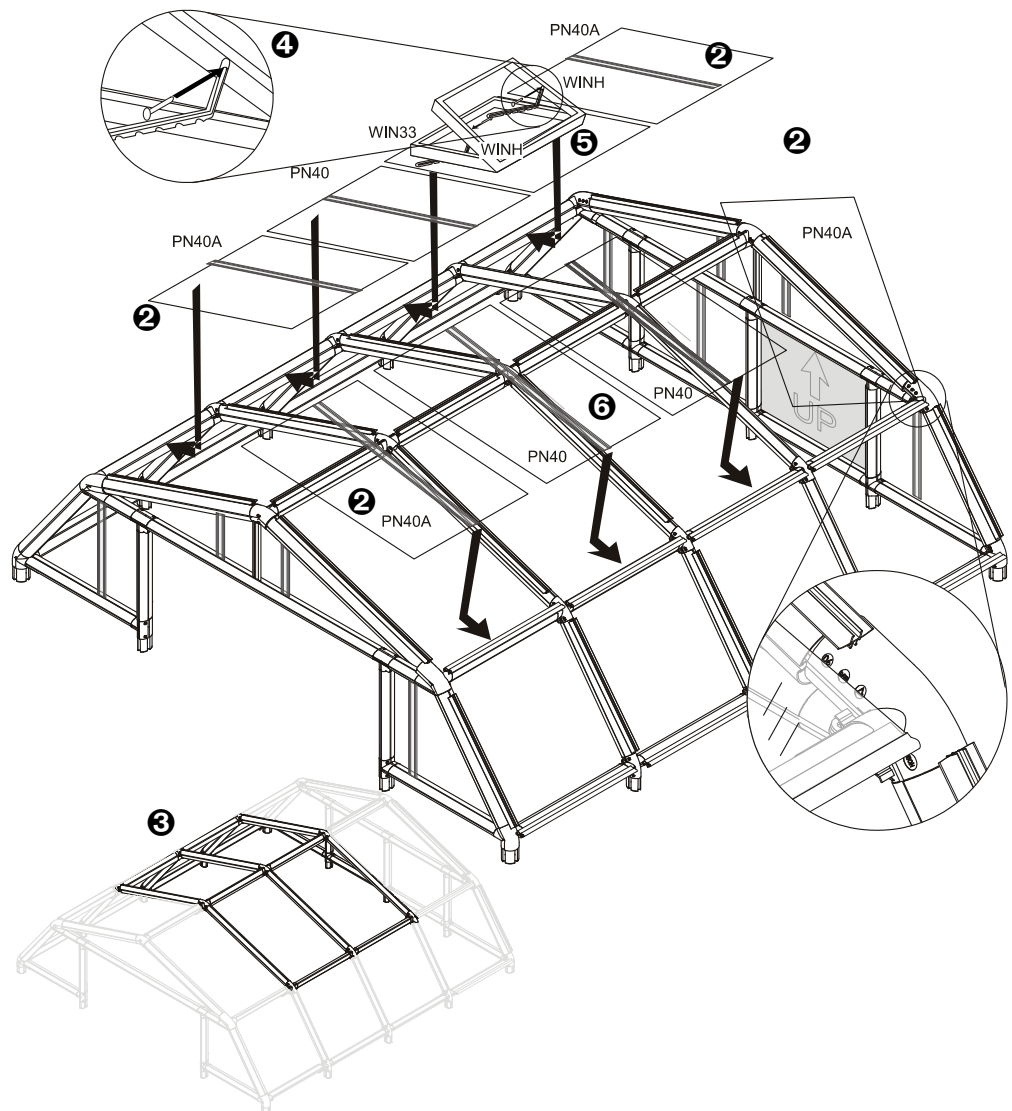
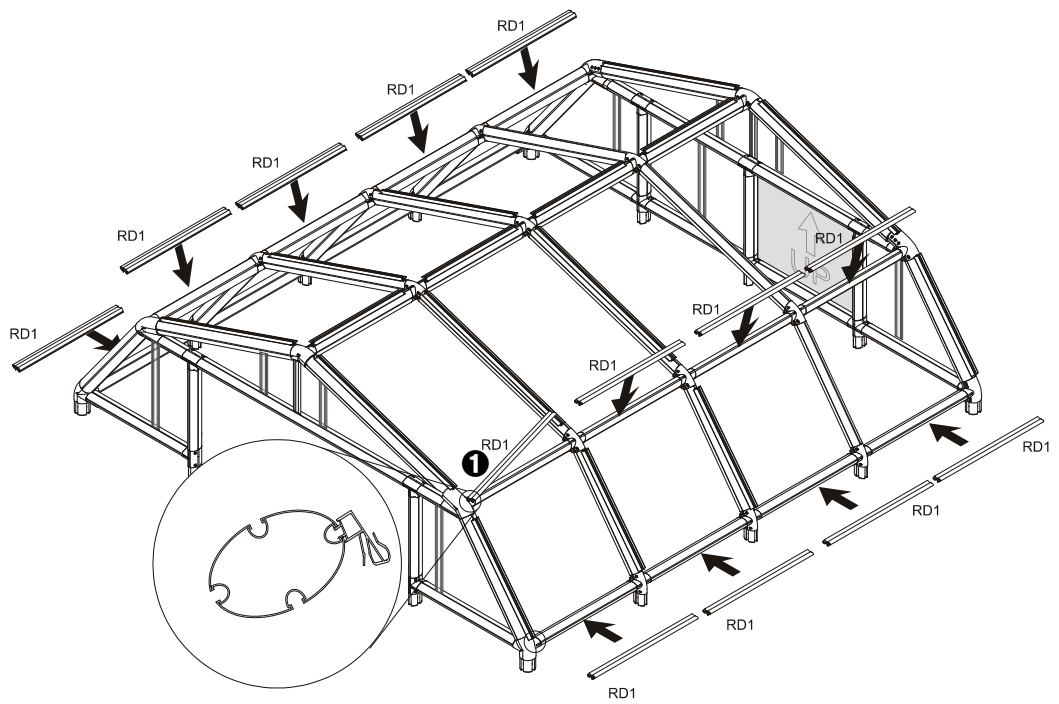

- ❶ Lock the sides of the Roof Vents and the PN40 using RC5 glazing elements. Make sure that the end of the RC glazing elements are in line with the bottom of the RD elements.
- ❷ Finish locking the panels into place by placing RC3 glazing elements across the top of the roof.

Important: In order to maintain the life of your greenhouse, it is essential to insert glazing elements fully and completely, using soapy water, as explained on page 2.

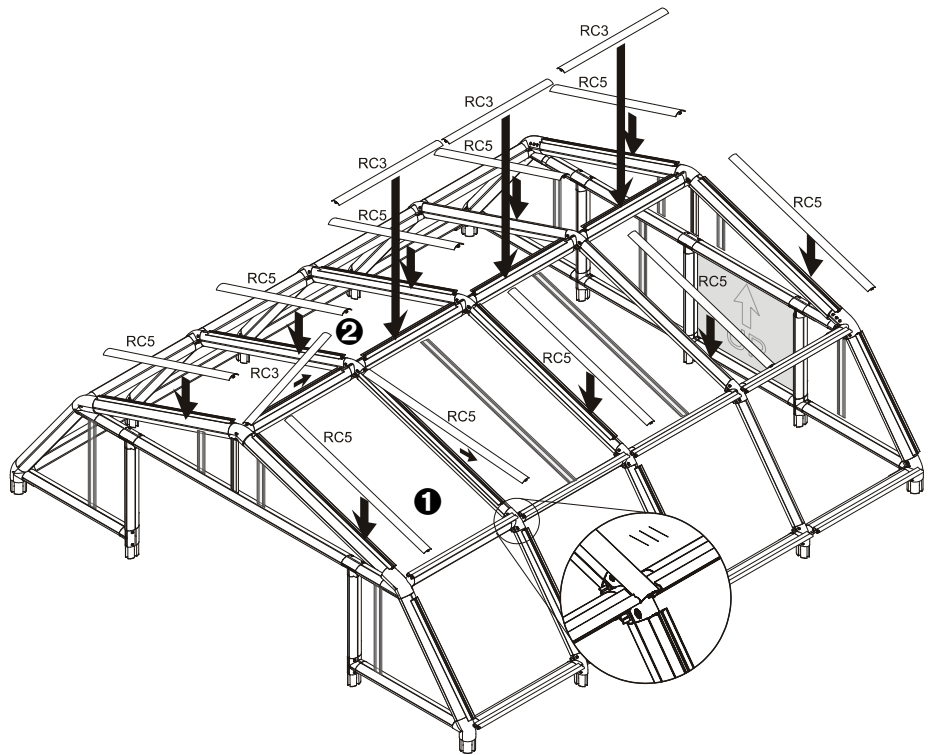

- ❸ Snap the roof caps in place on the top rib intersections.

Note: If you need to remove the roof caps push them on one side and then lift.

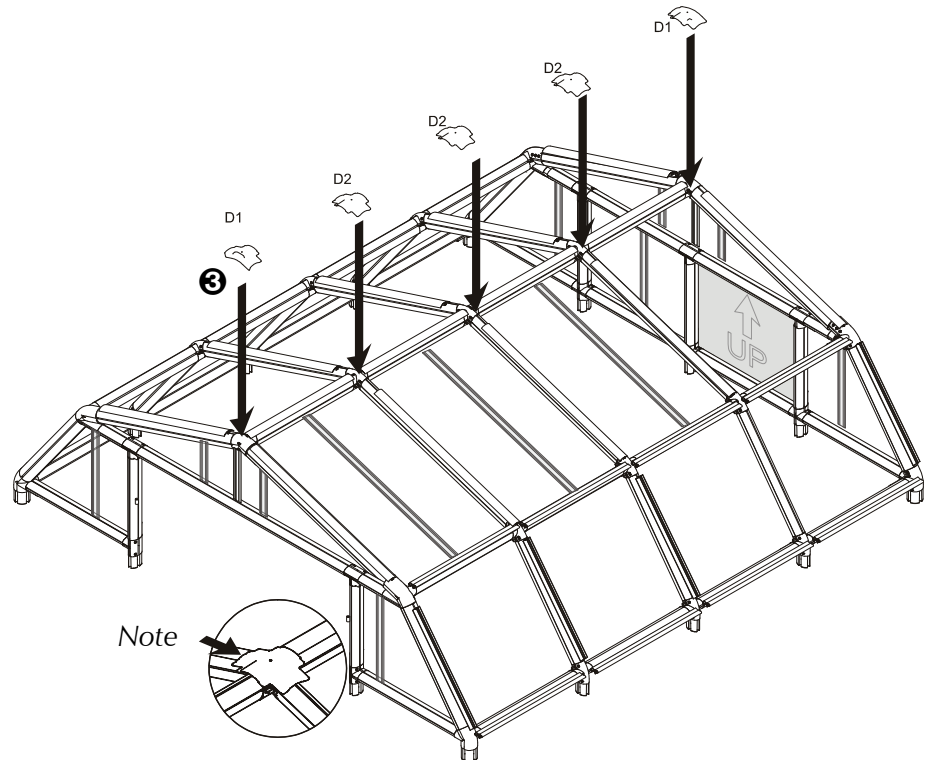

- ❶ Making sure that the plastic ID strip faces out, slide a PN2A panel in the lower RD1 element.
- ❷ Bend the panel until it enters the upper RD1 element.
- ❸ Continue with the rest of the PN2 and PN2A panels.

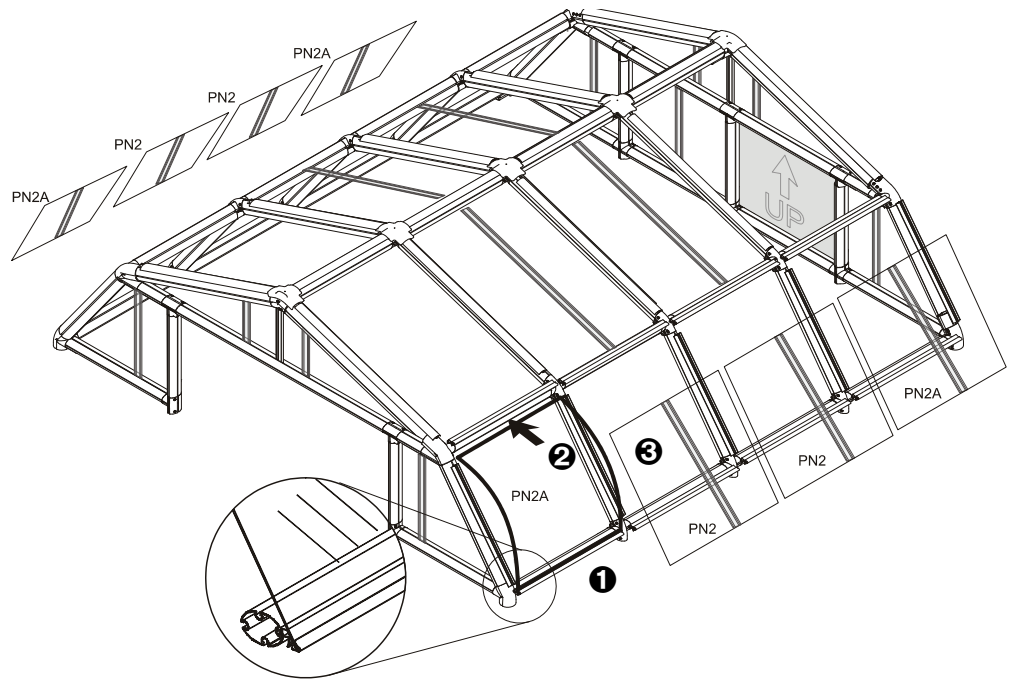

- ❹ Lock the lower panels into place using RC1 glazing elements. Make sure that the end of the RC glazing elements are in line with the bottom of the RD elements.
- ❺ Loosen the four screws holding the Louvered Window a few turns until you can remove the plastic protection cover. Retighten the screws.
- ❻ Remove the protection element from the outside of the window.

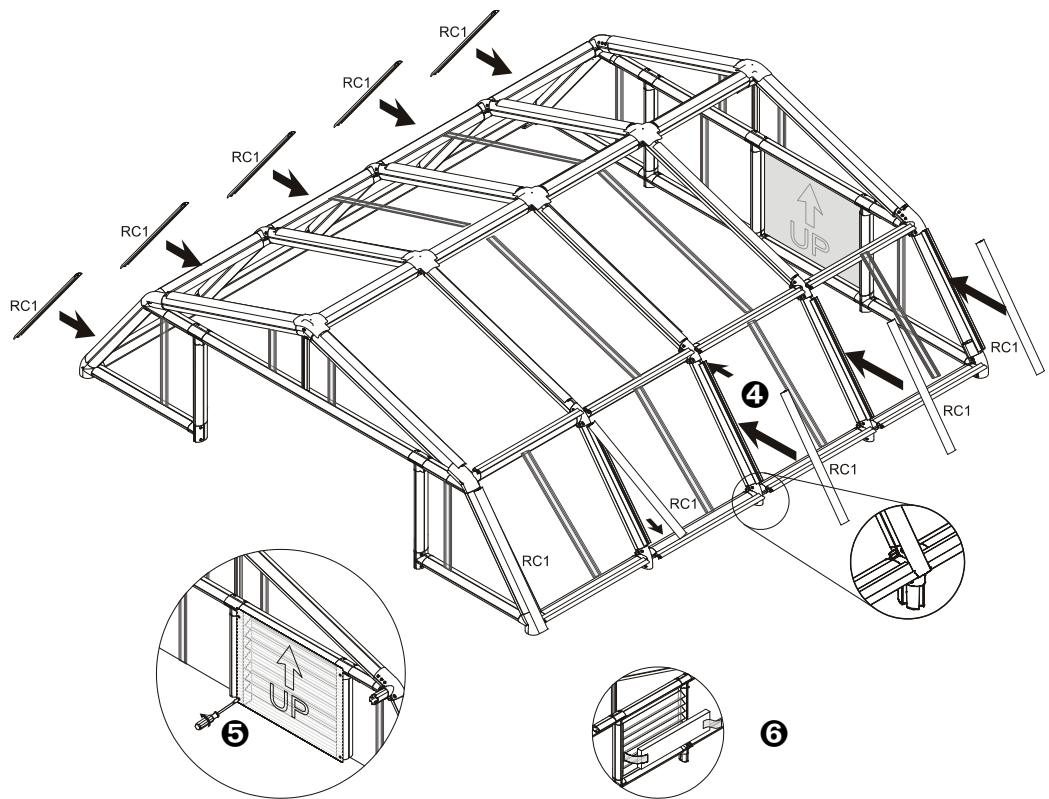

Note: You may now remove the plastic ID strips from the panels.

Important: In order to maintain the life of your greenhouse, it is essential to insert glazing elements fully and completely, using soapy water, as explained on page 2.

Cover the Walls

- 1 Put the R1 round profiles in place.
- 2 Insert two pins in each R1 profile to lock them in place. Do not insert pins in the inner (panel) channels.
- 3 Add the E1 oval profiles until the frame is completed.
- 4 Secure the E1 profiles with pins.

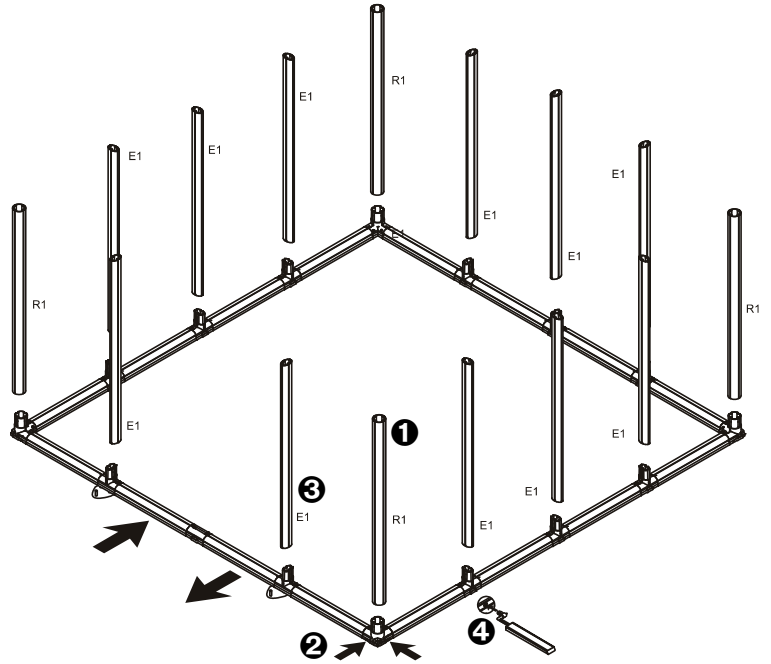

- 5 Take a PN1 panel with the plastic ID strip facing out, and put the panel in place by gently curving it so that it enters the side channels of the columns.
- 6 Lower the panel towards the frame and insert the lower end into the frame channels.
- 7 Continue with the rest of the PN1 panels.
- 8 Remove the ID strips from the panels.

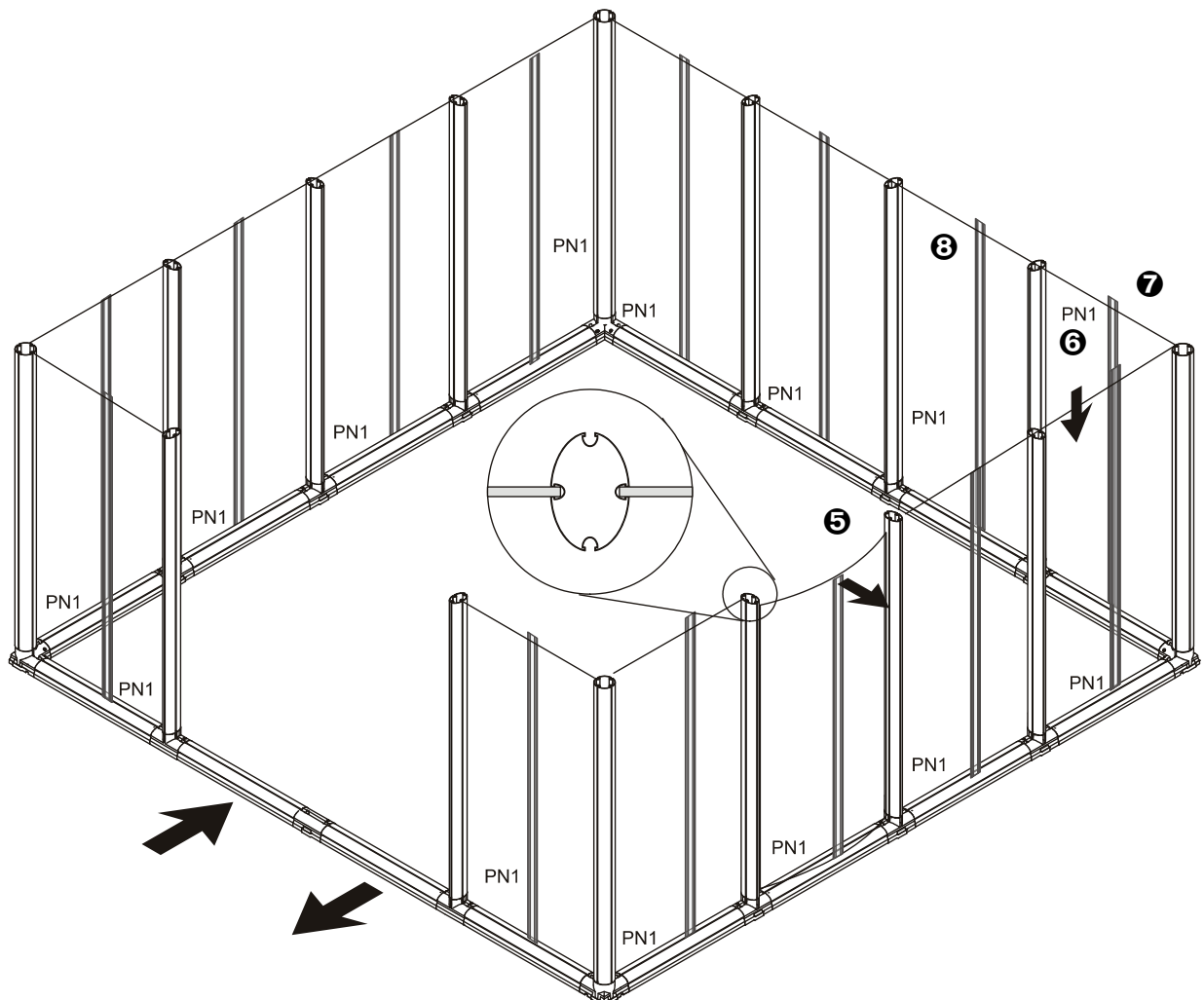

Raise the Roof

❶ Make sure that the roof is in the same orientation as the base and door. Lift the roof from both edges and walk through the door towards the back wall.

Note: You will need the help of another person for a short while to lift the roof and put it in place.

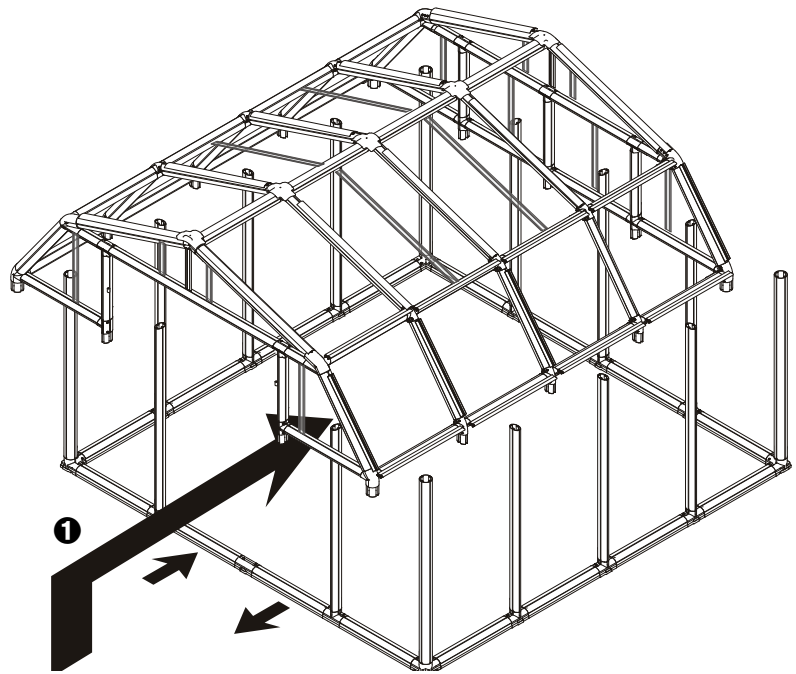

❷ Place the roof on the columns and circle around the greenhouse and insert the first 1 cm (1/2") of the roof connectors into the columns.

❸ Panel by panel, circle around the greenhouse and lower the roof into place. Use the GT1 glazing tool to guide the corners of the PN1 panel into the channels.

❹ Lock the roof in place with pins.

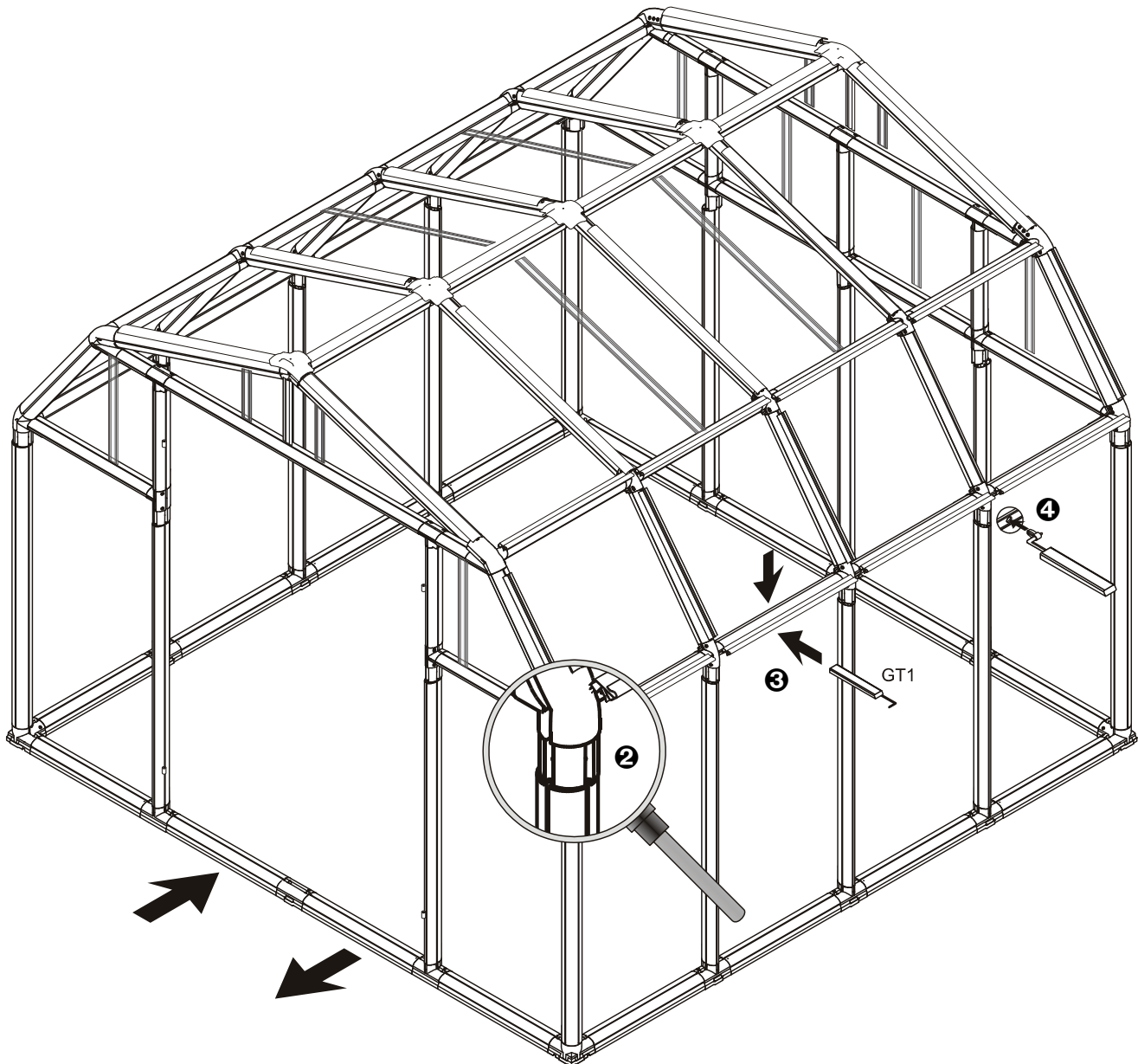

Seal Panels

❶ Take the roll of GF sealer, divide it as shown, and pull out enough for one side of a PN1 panel.

Note: If the GF Sealer is not divided it will not fit in the channel of the column profile.

❷ Cut it to length.

❸ Align it with the channel of the column profile with the double ridge facing the panel.

❹ Push it in to seal the panel using the GT1 glazing tool if needed.

❺ Repeat for the other PN1 panels and the panels in the front and back pediments.

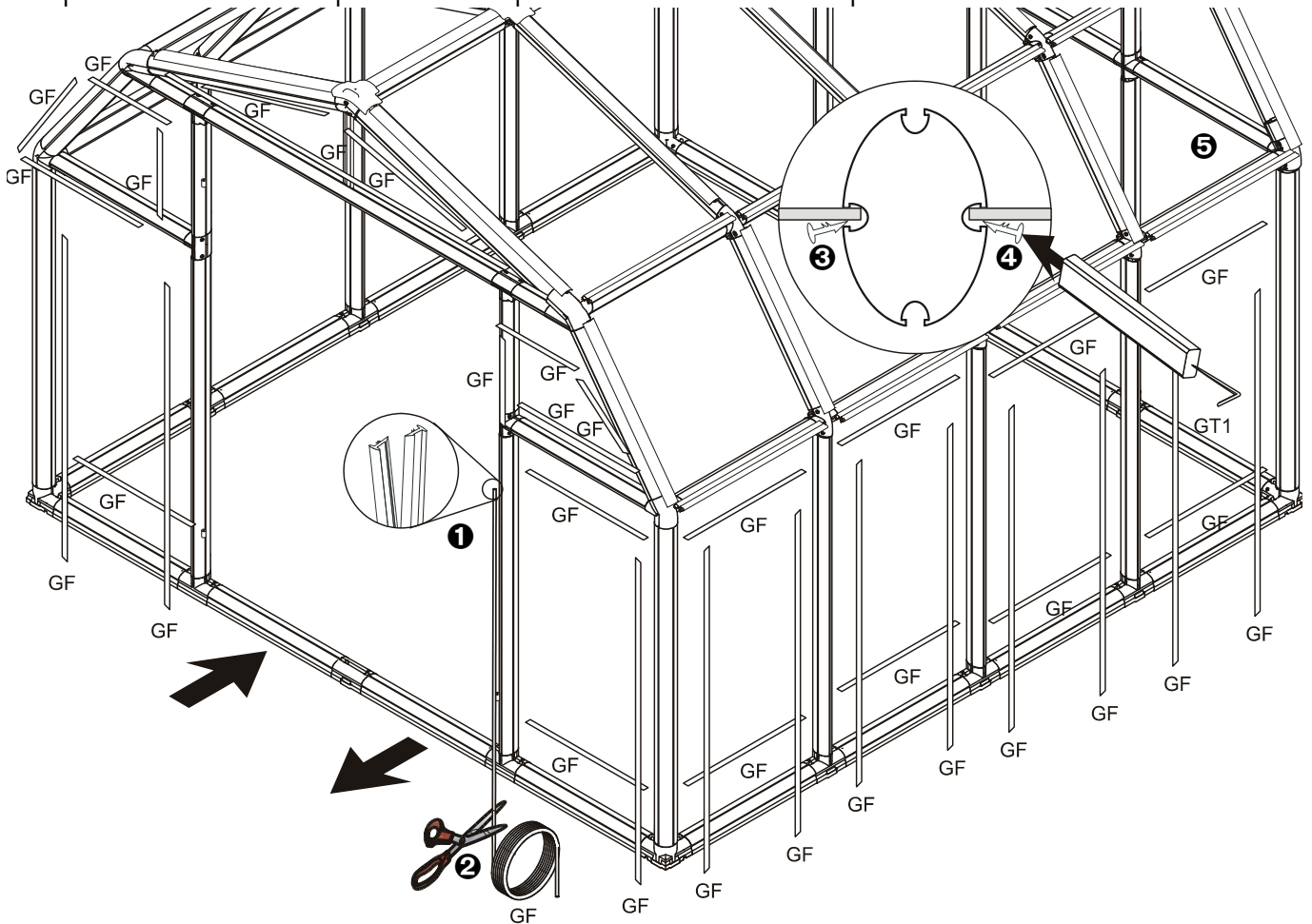

Prepare Doorway

❶ Insert a WDS Door Frame Sealer into the channel of the doorframe, as shown, using the GT1 Glazing tool as needed.

❷ Continue with the other side of the doorframe.

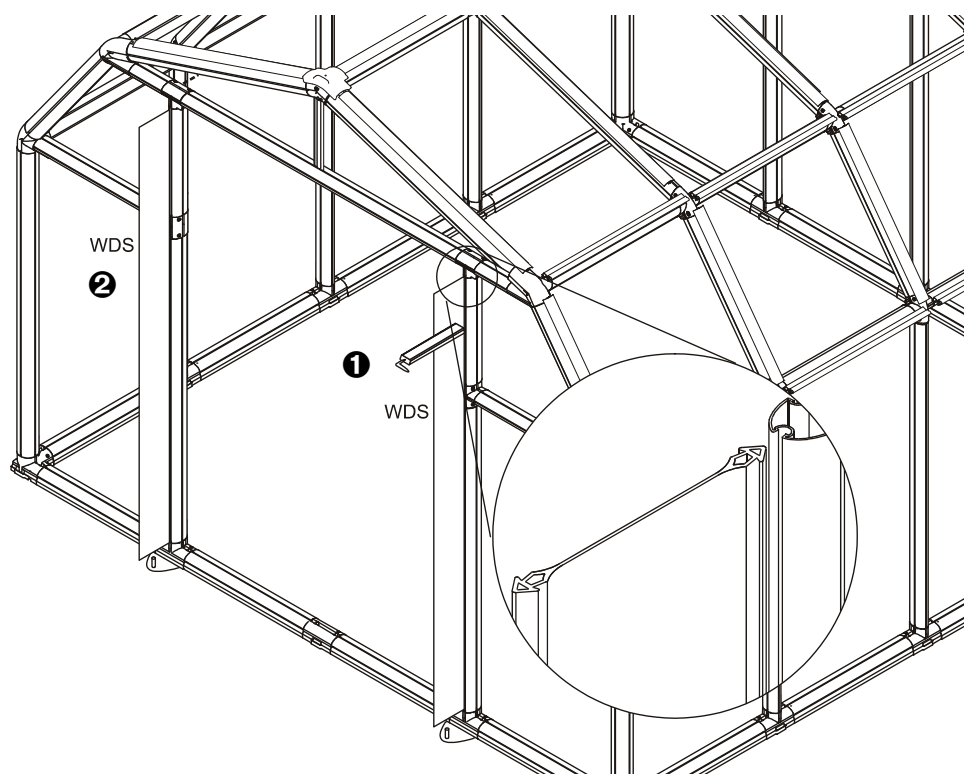

Assemble the Doors

Procedure A

- ❶ Assemble the profiles and connectors of the lower portion of the doors. Use the DoorH33 handle where shown on the left door.
- ❷ Put the PN1 panel in place with the plastic ID strip facing outwards.
- ❸ Assemble the upper portion of the door. Put the PN9 panel in place with the plastic ID strip facing outwards.
- ❹ Lock the door together with pins. You may now remove the plastic ID strips.

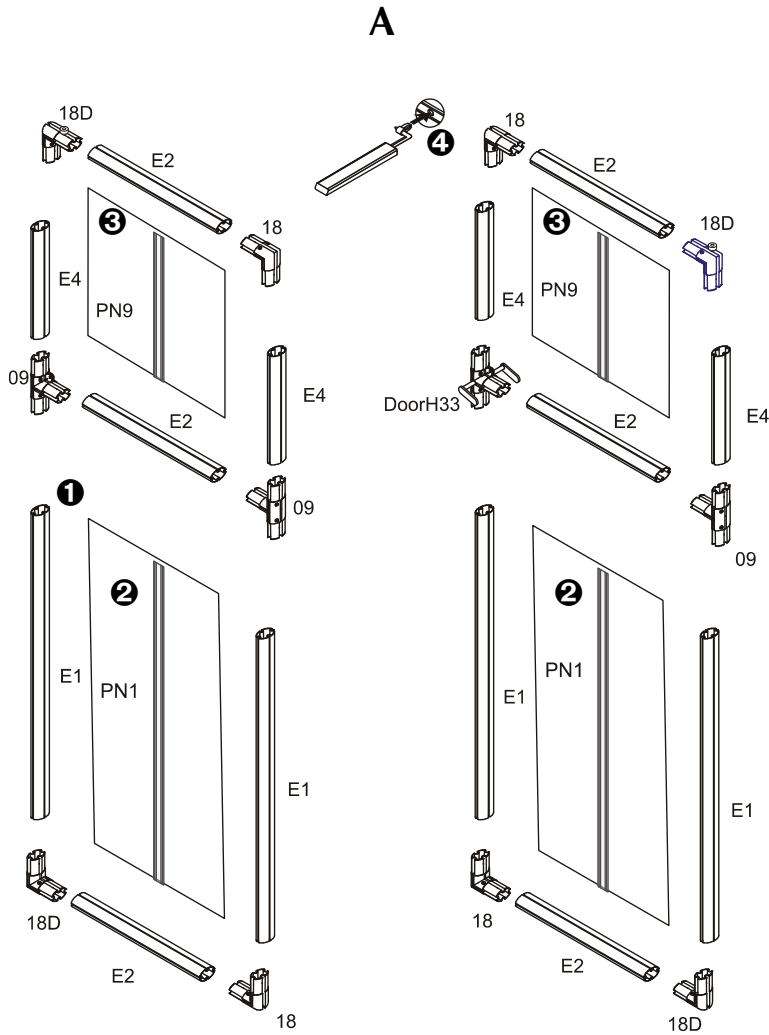

Procedure B

- ❺ Take the roll of GF sealer and divide it as shown.

Note: If the GF Sealer is not divided it will not fit in the channel of the column profile.

- ❻ Measure GF sealer for the edges of all panels.
- ❼ Align the GF with the channels of the column profiles with the double ridge facing the panels.
- ❽ Push them in to seal the panel using the GT1 glazing tool if needed.

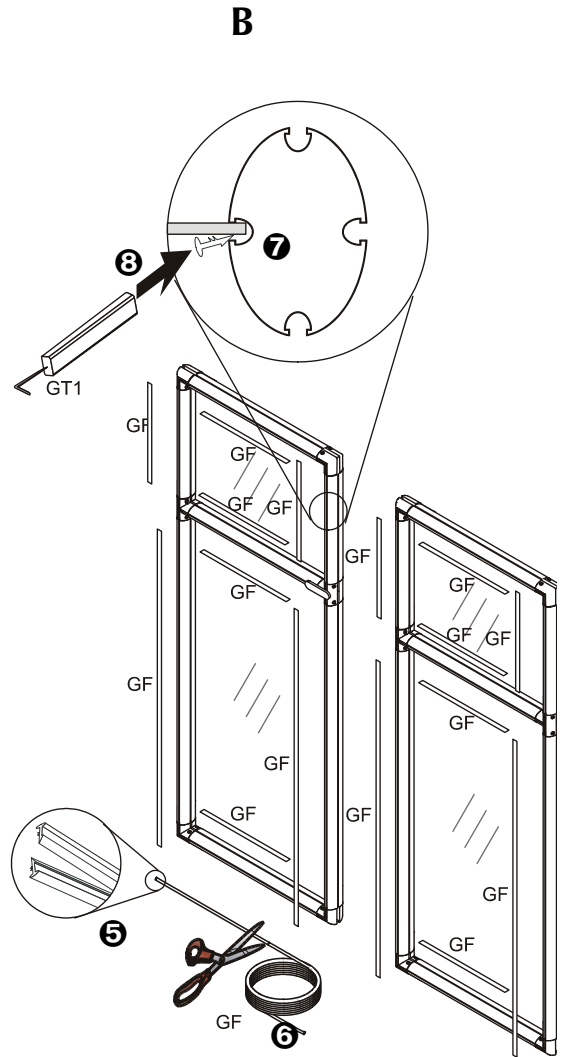

Hang the Doors

- 1 Cut two pieces of DSN Door Sealer for each door place them in bottom and outside channels as shown.
- 2 Cut one piece of DSN Door Sealer and place it in the upper channel of the door entrance.
- 3 Remove the four pins from both sides of the right pediment connector using the glazing tool.
- 4 Attach the Upper Hinge Right Door-1 with one AS80 screw and one ASL80 wing nut through the outer-most hole.
- 5 Place the right-hand door on the bottom hinge, keeping the WDS Door Frame Sealer the outside of the door.
- 6 Rotate the Upper Hinge Right Door-1 down so the pin enters the hole in the top of the door.
- 7 Secure the Upper Hinge Right Door-1 with an AS80 screw and one ASL80 wing nut through the inner-most hole.
- 8 Follow steps three through 7 to hang the left door using the Upper Hinge Left Door-1.

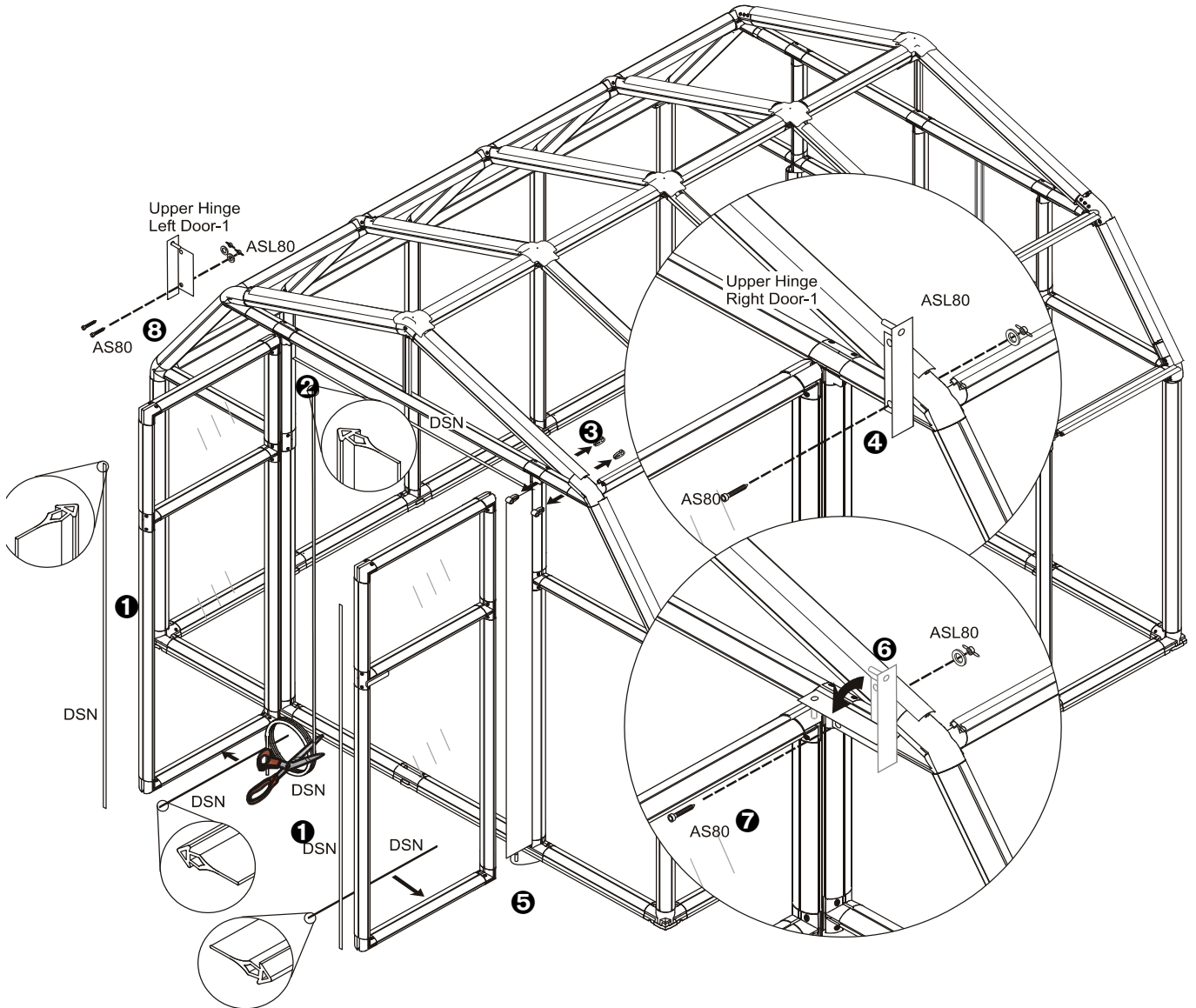

Assemble Door Latches

- 1 Go inside the greenhouse and close both doors.
- 2 Place the Lower Latch Plate against the lower part of the right door (without the handle) and make a mark where it can be attached without interfering with the opening and closing of the door.
- 3 Attach the Lower Latch Plate to the door with two PS 1/14" screws.
- 4 Attach the Inner Door Latch to the Lower Bar Connector using four PH screws.

Note: Make sure that the latch slider enters the hole in the base profile before continuing.

- 5 Place the Upper Latch Plate against the upper part of the right door (without the handle) and make a mark where it can be attached without interfering with the opening and closing of the door.
- 6 Attach the Upper Latch Plate to the door with two PS 1/14" screws.
- 7 Attach the Inner Door Latch to the Lower Bar Connector using four PH screws.

Note: Make sure that the latch slider enters the hole in the pediment profile before continuing.

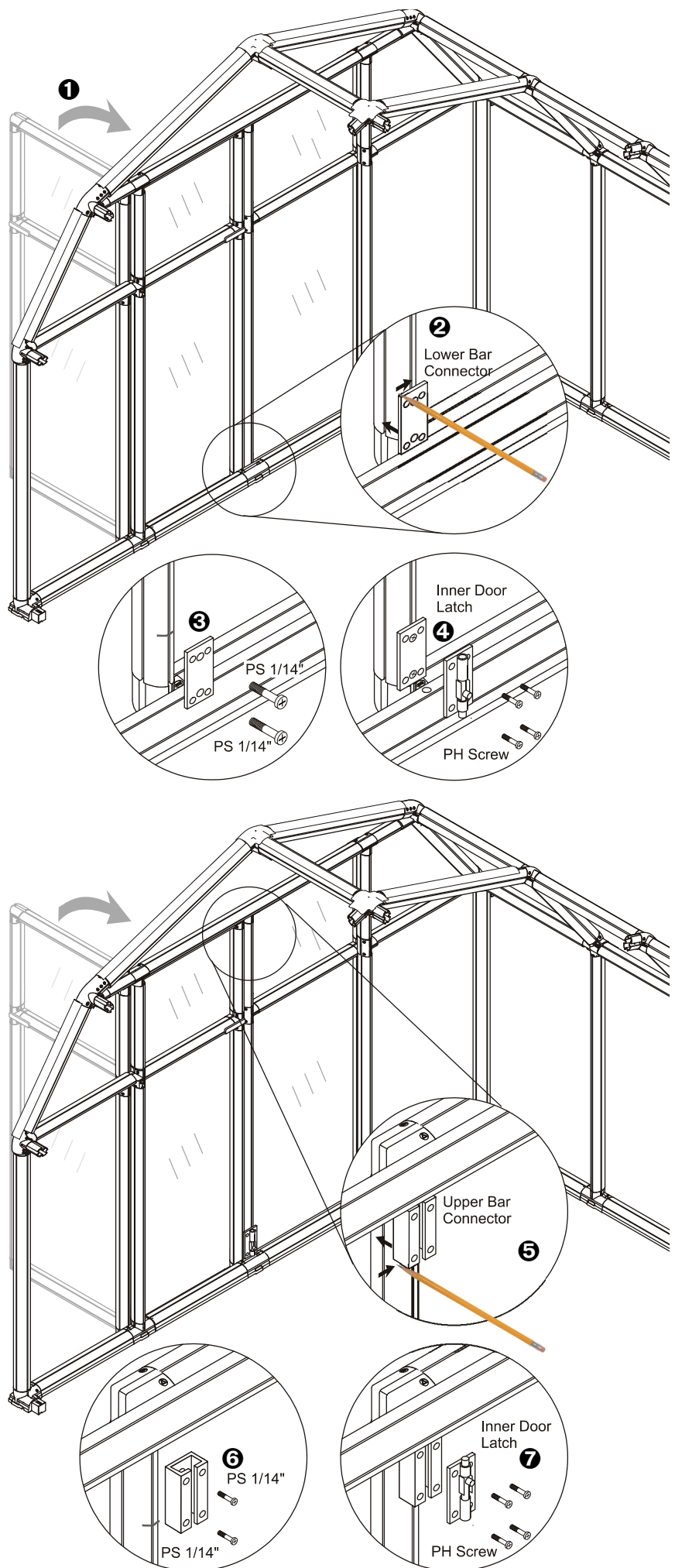

Seal the Door

- ❶ Go outside your greenhouse and insert the free end of the WDS Door Frame Sealer into the Door. Use the GT1 Glazing tool as needed.
- ❷ Do the same thing for the other door.

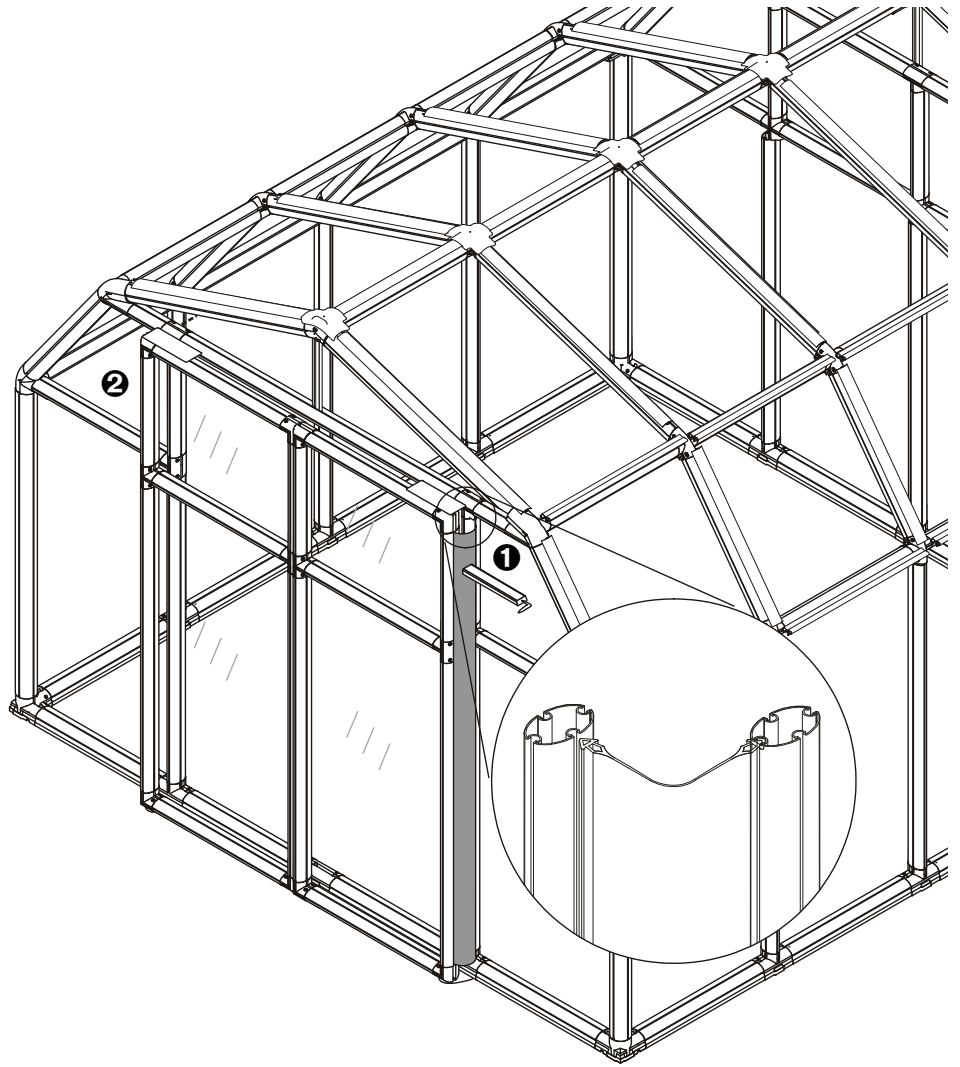

Attach Door Holder

- 1 Make a hole in the left door, about a centimeter below the pin, with an awl.
- 2 Screw in the hook latch.
- 3 Repeat this process with the right door.
- 4 Make a hole in the left part of the frame, about a centimeter below the pin, with an awl.
- 5 Screw in the eye for the hook latch.
- 6 Repeat this process for the right door.

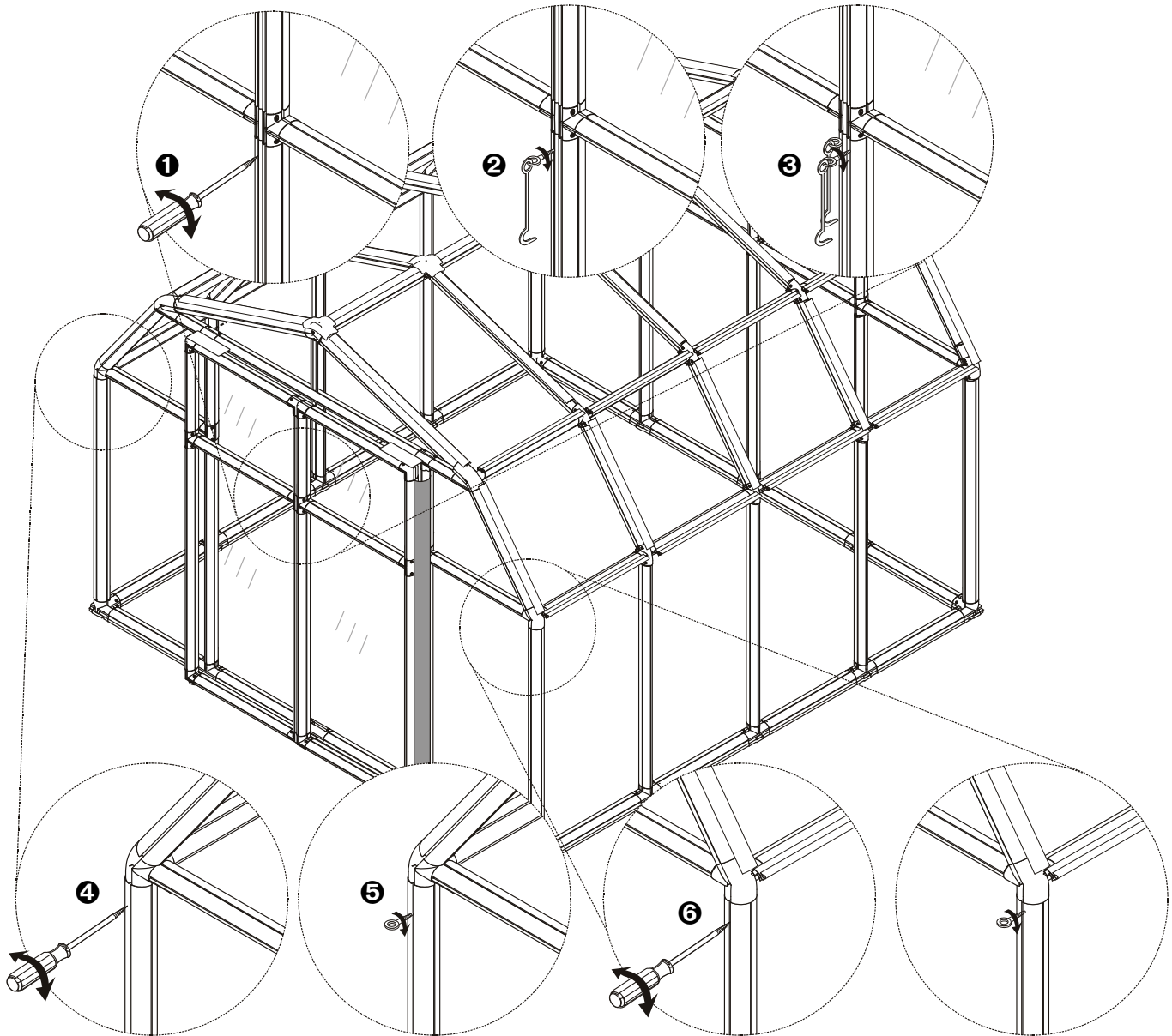

To hold the door open insert the hook latch on the door to the eye on the frame.

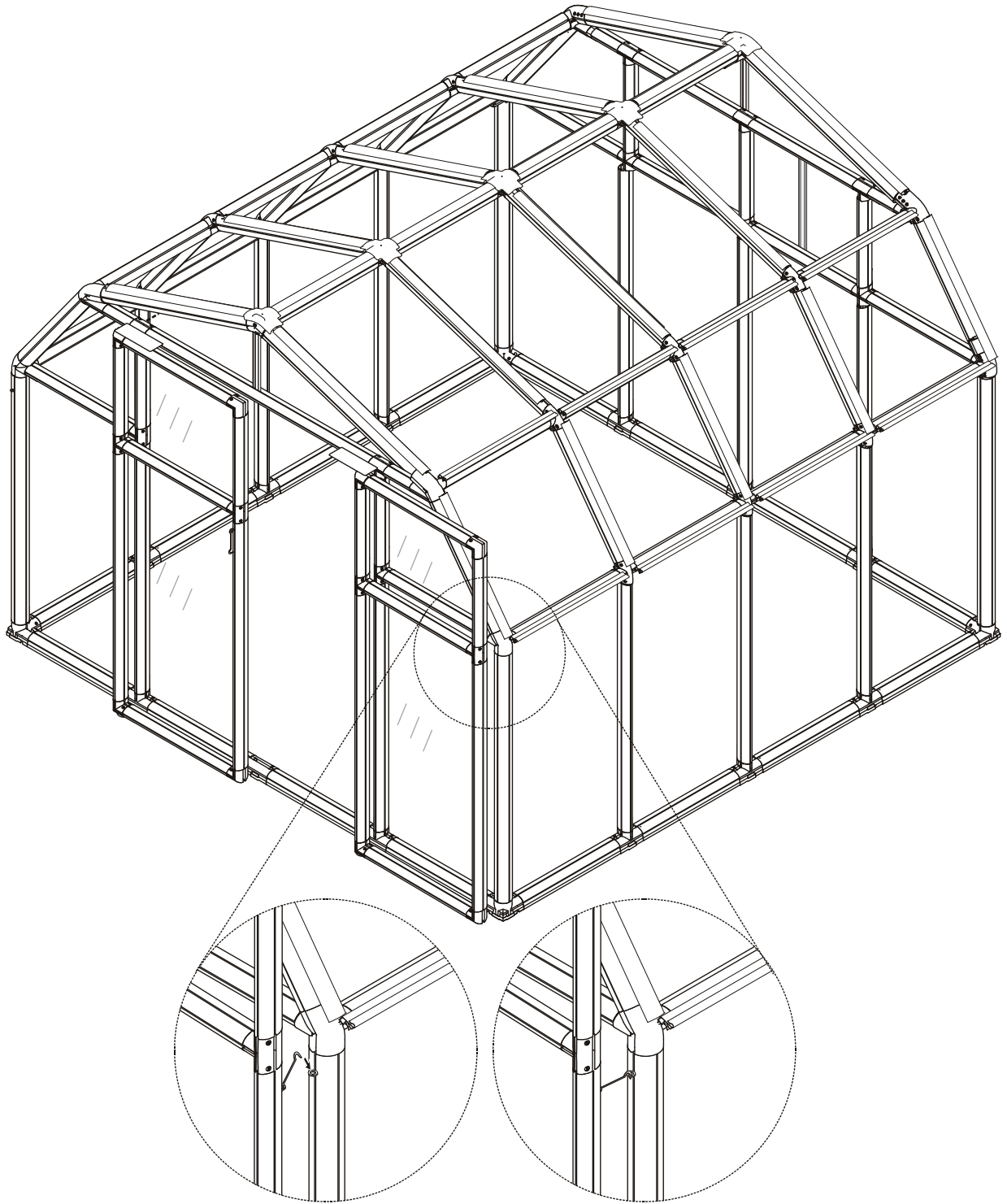

Final Touches

Go inside your new Greenhouse and seal any gaps between the PN2 and PN2A panels and the profiles using SF soft foam insulation. Cut pieces of SF soft foam insulation 2.5 cm (1") long, remove the adhesive backing, and place where shown, making sure that the area is clean and dry.

Congratulations! Your Greenhouse is now completed. You will find it easy to clean and maintain.

Put this manual in a safe place so you can refer to it if you decide to add options or need to make a repair.

For your safety and convenience, please take note of the following:

- Examine your Greenhouse for sharp edges and trim with a razor knife if necessary.
- It is important to clear your Greenhouse of snow in the winter.
- If you live in a hot climate, where outside temperatures exceed 46° C (115° F) in the sun or 36° C (99° F) in the shade, this may cause the temperature inside the greenhouse to exceed 55° C (131° F). Such conditions may harm your plants and will damage the greenhouse by warping structural profiles. In order to prevent damage:
 - Ensure good ventilation during hot days.
 - Install a shading screen, such as the Rion ShadeNet (available as an option).
- Always close roof vents in high winds.

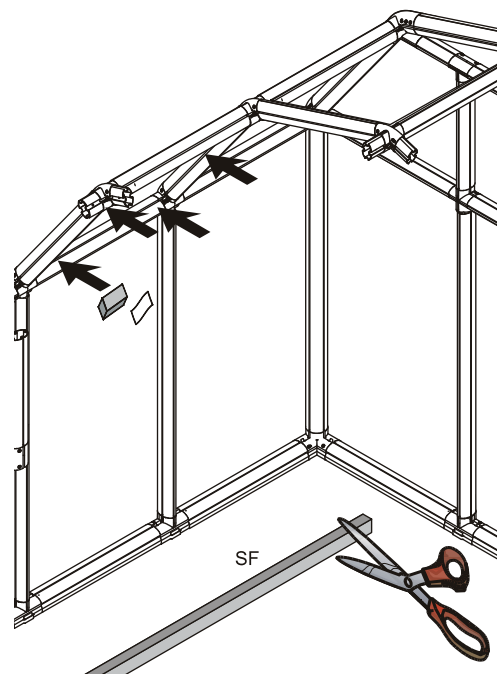

Rion offers a wide range of options for your new Greenhouse, including modular shelves, irrigation systems, additional windows, automatic window openers, and others. See our web page at <http://www.rion.com> for a complete listing.

Thank you for your purchase. We wish you many years of pleasure with your greenhouse. Please feel free to contact us with any questions, comments, or suggestions.

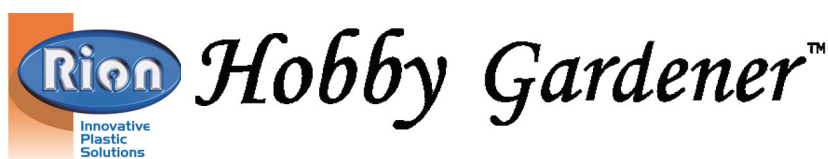

Rion Ltd.
Cabri 25120 ● Israel
Tel: +972-4-995-2666, Fax: +972-4-995-2677
email: rion@rion.com
homepage: <http://www.rion.com>